

CR, CRI, CRN

Vertical multi-stage centrifugal pumps
50 Hz



be
think
innovate

GRUNDFOS 

1. Product introduction	3	LiqTec	84
Performance range	4	Sensors	85
Applications	6		
Product range	7	9. Variants	86
Pump	9		
Motor	9	10. Further product information	87
Terminal box positions	10	WebCAPS	87
Ambient temperature	10	WinCAPS	88
Viscosity	10	GO CAPS	89
2. Construction	11		
CR 1s, 1, 3, 5, 10, 15 and 20	11		
CRI, CRN 1s, 1, 3, 5, 10, 15 and 20	11		
CR 32, 45, 64 and 90	12		
CRN 32, 45, 64 and 90	12		
CR 120 and 150	13		
CRN 120 and 150	13		
Type keys	14		
3. Operating and inlet pressures	15		
Maximum operating pressure and liquid temperature	15		
Operating range of the shaft seal	16		
Maximum inlet pressure	17		
4. Selection and sizing	18		
Selection of pumps	18		
How to read the curve charts	21		
Guidelines to performance curves	21		
5. Performance curves and technical data	22		
CR 1s	22		
CRI, CRN 1s	24		
CR 1	26		
CRI, CRN 1	28		
CR 3	30		
CRI, CRN 3	32		
CR 5	34		
CRI, CRN 5	36		
CR 10	38		
CRI, CRN 10	40		
CR 15	42		
CRI, CRN 15	44		
CR 20	46		
CRI, CRN 20	48		
CR 32	50		
CRN 32	52		
CR 45	54		
CRN 45	56		
CR 64	58		
CRN 64	60		
CR 90	62		
CRN 90	64		
CR 120	66		
CRN 120	68		
CR 150	70		
CRN 150	72		
6. Motor data	74		
Standard motors for CR, CRI, CRN, 50 Hz	74		
7. Pumped liquids	75		
8. Accessories	77		
Pipe connection	77		

1. Product introduction

This data booklet deals with Grundfos CR, CRI and CRN pumps.



CR 5381

Fig. 1 CR, CRI and CRN pumps

CR, CRI and CRN pumps are vertical multi-stage, centrifugal pumps. The in-line design of the pumps enables installation in a horizontal one-pipe system where the suction and discharge ports are in the same horizontal level and have the same pipe dimensions. This design provides a more compact pump design and pipework.

CR pumps are available in various sizes and various numbers of stages to deliver the flow and pressure required.

CR pumps are designed for a variety of applications ranging from the pumping of potable water to the pumping of chemicals. The pumps are therefore suitable for a wide diversity of pumping systems where the performance and material of the pump meet specific demands.

A CR pump consists of two main components: the motor and the pump unit.

The motor is a Grundfos motor designed to EN standards.

The pump unit consists of optimised hydraulics, various types of connections, a sleeve, a pump head and various other parts.

CR pumps are available in various material versions according to the pumped liquid.

Performance range

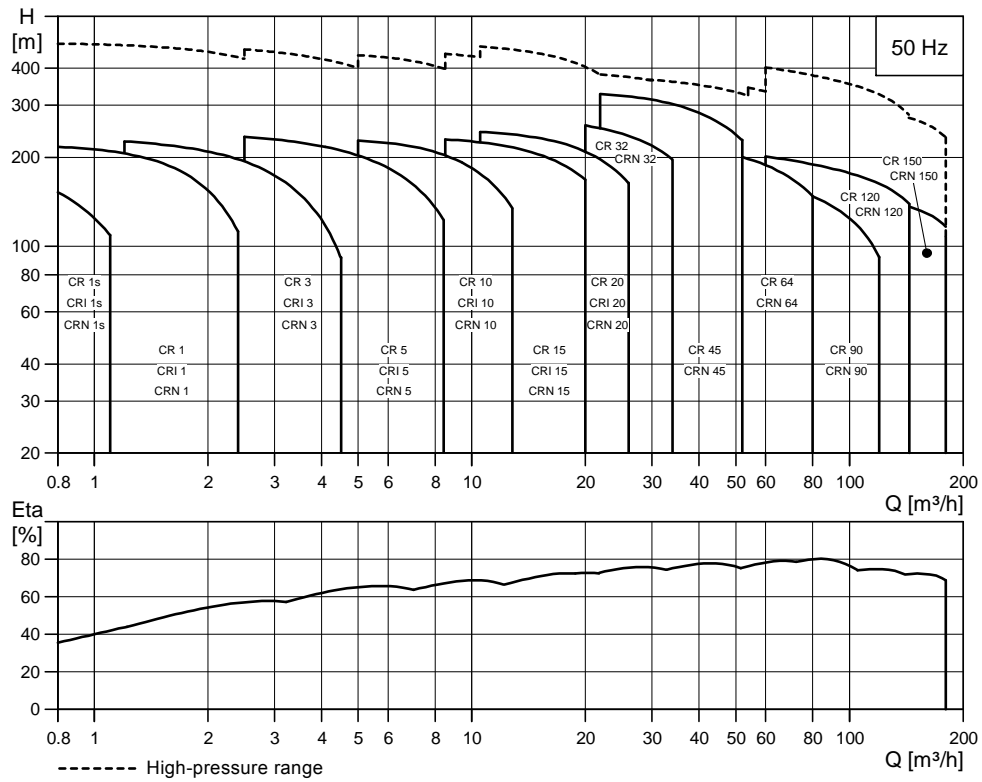

Fig. 2 Performance range, CR, CRI and CRN

TM02 1192 1013

EuP ready

The CR, CRI, CRN pumps are energy-optimised and comply with the EuP Directive (Commission Regulation (EC) No 547/2012) which has been effective since 1 January 2013. As from this date, all pumps will be classified/graduated in a new energy minimum efficiency index (MEI).

Minimum efficiency index

Minimum efficiency index (MEI) means the dimensionless scale unit for hydraulic pump efficiency at best efficiency point (BEP), part load (PL) and overload (OL). The Commission Regulation (EU) sets efficiency requirements to $MEI \geq 0.10$ as from 1 January 2013 and $MEI \geq 0.40$ as from 1 January 2015. An indicative benchmark for best-performing water pump available on the market as from 1 January 2013 is determined in the Regulation.

- The benchmark for most efficient water pumps is $MEI \geq 0.70$.
- The efficiency of a pump with a trimmed impeller is usually lower than that of a pump with the full impeller diameter. The trimming of the impeller will adapt the pump to a fixed duty point, leading to reduced energy consumption. The minimum efficiency index (MEI) is based on the full impeller diameter.
- The operation of this water pump with variable duty points may be more efficient and economic when controlled, for example, by the use of a variable-speed drive that matches the pump duty to the system.
- Information on benchmark efficiency is available at <http://europump.eu/efficiencycharts>.

Minimum efficiency index (MEI)

Pump type	MEI
CR 1s-3	0.54
CR 1-3	> 0.70
CR 3-3	> 0.70
CR 5-3	0.57
CR 10-3	> 0.70
CR 15-3	> 0.70
CR 20-3	> 0.70
CR 32-3	> 0.70
CR 45-3	> 0.70
CR 64-3	> 0.70
CR 90-3	> 0.70

Applications

Application	CR, CRI	CRN
Water supply		
Filtration and transfer at waterworks	•	○
Distribution from waterworks	•	○
Pressure boosting in mains	•	○
Pressure boosting in high-rise buildings, hotels, etc.	•	○
Pressure boosting for industrial water supply	•	○
Industry		
Pressure boosting		
Process-water systems	•	•
Washing and cleaning systems	•	•
Vehicle-washing tunnels	•	○
Firefighting systems	•	-
Liquid transfer		
Cooling and air-conditioning systems (refrigerants)	•	○
Boiler feed and condensate systems	•	○
Machine tools (cooling lubricants)	•	•
Aquafarming*	•	○
Special transfer duties		
Oils and alcohols	•	•
Acids and alkalis*	-	•
Glycol and coolants	•	-
Water treatment		
Ultra-filtration systems	-	•
Reverse osmosis systems*	-	•
Softening, ionising, demineralising systems	-	•
Distillation systems	-	•
Separators	•	•
Swimming baths*	-	•
Irrigation		
Field irrigation (flooding)	•	○
Sprinkler irrigation	•	○
Drip-feed irrigation	•	○

• Recommended version.

○ Alternative version.

* CRT version available.

For further information about CRT pumps, see section 7. *Pumped liquids*, page 75, or related CRT, CRTE data booklet available on www.Grundfos.com (WebCAPS).

Product range

Range	CR 1s	CR 1	CR 3	CR 5	CR 10	CR 15	CR 20
Rated flow rate [m ³ /h]	0.8	1	3	5	10	15	20
Liquid temperature [°C]	-20 - +120						
Liquid temperature [°C], on request	-40 - +180						
Maximum pump efficiency [%]	35	48	58	66	70	72	72
CR pumps							
Flow rate [m ³ /h]	0.3 - 1.1	0.7 - 2.4	1.2 - 4.5	2.5 - 8.5	5 - 13	9 - 24	11 - 29
Maximum pressure [bar]	21	22	24	24	22	23	25
High pressure [bar], on request (CRN)	-	47	41	47	44	47	48
Motor power [kW]	0.37 - 1.1	0.37 - 2.2	0.37 - 3	0.37 - 5.5	0.37 - 7.5	1.1 - 15	1.1 - 18.5
Version							
CR: Cast iron and stainless steel EN 1.4301/AISI 304	•	•	•	•	•	•	•
CRI: Stainless steel EN 1.4301/AISI 304	•	•	•	•	•	•	•
CRN: Stainless steel EN 1.4401/AISI 316	•	•	•	•	•	•	•
CRT: Titanium	See the CRT, CRTE data booklet available on www.Grundfos.com (WebCAPS).						
CR pipe connection							
Oval flange (BSP)	Rp 1	Rp 1	Rp 1	Rp 1 1/4	Rp 1 1/4	Rp 2	Rp 2
Oval flange (BSP), on request	Rp 1 1/4	Rp 1 1/4	Rp 1 1/4	Rp 1	Rp 1 1/4 Rp 2	Rp 2 1/2	Rp 2 1/2
Flange	DN 25/ DN 32	DN 25/ DN 32	DN 25/ DN 32	DN 25/ DN 32	DN 40	DN 50	DN 50
Flange, on request	-	-	-	-	DN 50	-	-
CRI pipe connection							
Oval flange (BSP)	Rp 1	Rp 1	Rp 1 1/4	Rp 1 1/4	Rp 1 1/2	Rp 2	Rp 2
Oval flange (BSP), on request	Rp 1 1/4	Rp 1 1/4	Rp 1	Rp 1	Rp 2	-	-
Flange	DN 25/ DN 32	DN 25/ DN 32	DN 25/ DN 32	DN 25/ DN 32	DN 40	DN 50	DN 50
Flange, on request	-	-	-	-	DN 50	-	-
PJE coupling (Victaulic)	R 1 1/4 DN 32	R 1 1/4 DN 32	R 1 1/4 DN 32	R 1 1/4 DN 32	R 2 DN 50	R 2 DN 50	R 2 DN 50
Clamp coupling (L-coupling)	∅48.3	∅48.3	∅48.3	∅48.3	∅60.3	∅60.3	∅60.3
Union (+GF+)	G 2	G 2	G 2	G 2	G 2 3/4	G 2 3/4	G 2 3/4
CRN pipe connection							
Oval flange (BSP)	Rp 1	Rp 1	Rp 1 1/4	Rp 1 1/4	Rp 1 1/2	Rp 2	Rp 2
Oval flange (BSP), on request	Rp 1 1/4	Rp 1 1/4	Rp 1	Rp 1	Rp 2	-	-
Flange	DN 25/ DN 32	DN 25/ DN 32	DN 25/ DN 32	DN 25/ DN 32	DN 40	DN 50	DN 50
Flange, on request	-	-	-	-	DN 50	-	-
PJE coupling (Victaulic)	R 1 1/4 DN 32	R 1 1/4 DN 32	R 1 1/4 DN 32	R 1 1/4 DN 32	R 2 DN 50	R 2 DN 50	R 2 DN 50
Clamp coupling (L-coupling)	∅48.3	∅48.3	∅48.3	∅48.3	∅60.3	∅60.3	∅60.3
Union (+GF+)	G 2	G 2	G 2	G 2	G 2 3/4	G 2 3/4	G 2 3/4

- Standard.
- Available.

Range	CR 32	CR 45	CR 64	CR 90	CR 120	CR 150
Rated flow rate [m ³ /h]	32	45	64	90	120	150
Liquid temperature [°C]	-30 - +120 ¹⁾			-30 - +120 ¹⁾ and 2)		
Liquid temperature [°C], on request	-40 - +180			-		
Maximum pump efficiency [%]	78	79	80	81	75	72
CR pumps						
Flow rate [m ³ /h]	15 - 40	22 - 58	30 - 85	45 - 120	60 - 160	75 - 180
Maximum pressure [bar]	28	33	22	20	21	19
High pressure [bar], on request (CRN)	39	39	39	41	41	39
Motor power [kW]	1.5 - 30	3 - 45	4 - 45	5.5 - 45	11 - 75	11 - 75
Version						
CR: Cast iron and stainless steel EN 1.4301/AISI 304	•	•	•	•	•	•
CRI: Stainless steel EN 1.4301/AISI 304	○	○	○	○	-	-
CRN: Stainless steel EN 1.4401/AISI 316	•	•	•	•	•	•
CRT: Titanium	See the CRT, CRTE data booklet available on www.Grundfos.com (WebCAPS).					
CR pipe connection						
Oval flange (BSP)	-	-	-	-	-	-
Oval flange (BSP), on request	-	-	-	-	-	-
Flange	DN 65	DN 80	DN 100	DN 100	DN 125	DN 125
Flange, on request	DN 80	DN 100	DN 125	DN 125	DN 150	DN 150
CRI pipe connection						
Oval flange (BSP)	-	-	-	-	-	-
Oval flange (BSP), on request	-	-	-	-	-	-
Flange	-	-	-	-	-	-
Flange, on request	-	-	-	-	-	-
PJE coupling (Victaulic)	-	-	-	-	-	-
Clamp coupling (L-coupling)	-	-	-	-	-	-
Union (+GF+)	-	-	-	-	-	-
CRN pipe connection						
Oval flange (BSP)	-	-	-	-	-	-
Oval flange (BSP), on request	-	-	-	-	-	-
Flange	DN 65	DN 80	DN 100	DN 100	DN 125	DN 125
Flange, on request	DN 80	DN 100	DN 125	DN 125	DN 150	DN 150
PJE coupling (Victaulic)	3" ²⁾	4" ³⁾	4" ³⁾	4" ³⁾	-	-
Clamp coupling (L-coupling)	-	-	-	-	-	-
Union (+GF+)	-	-	-	-	-	-

- Standard.
- Available.

¹⁾ CRN 32 to 150 with HQQE shaft seal: -40 - +120 °C.

²⁾ CR, CRN 120 and 150 with 55 or 75 kW motors with HBQE shaft seal: 0-120 °C.

³⁾ On request. See the CR "Custom-built pumps" data booklet available on www.grundfos.com (WebCAPS).

Pump

The CR pumps are non-self-priming, vertical multi-stage centrifugal pumps.

The pumps are available with a Grundfos standard motor.

The pump consists of a base and a pump head. The chamber stack and the sleeve are secured between the base and the pump head by means of staybolts. The base has suction and discharge ports on the same level (in line). All pumps are fitted with a maintenance-free mechanical shaft seal of the cartridge type.

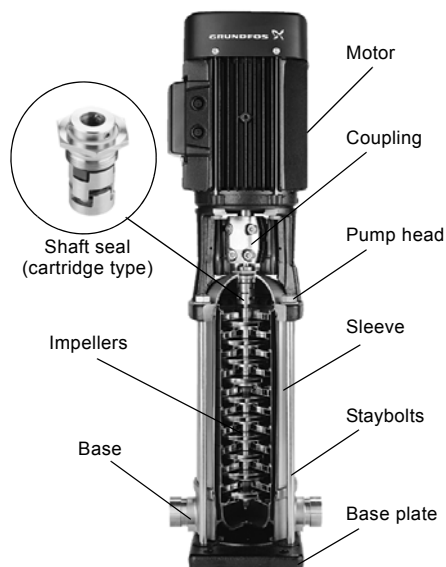

Fig. 3 CR pump

GR5357 - GR3395

Motor

Grundfos MG standard and Siemens motors

CR, CRI and CRN pumps are fitted with a totally enclosed, fan-cooled, 2-pole Grundfos standard motor with principal dimensions to EN standards.

Electrical tolerances according to EN 60034.

CR, CRI, CRN pumps are fitted with three-phase MG motors as standard.

CR, CRI, CRN pumps from 0.37 to 2.2 kW are also available with single-phase motors (1 x 220-230/240 V). See WinCAPS or WebCAPS.

Grundfos E-motors

We also offer frequency-controlled CRE, CRIE and CRNE pumps which are the ideal choice for a number of applications characterised by a demand for variable flow at constant pressure. These pumps are suited for water supply systems and pressure boosting as well as for industrial applications. Depending on the application, the pumps offer energy savings, increased comfort and improved processing.

See the CRE, CRIE and CRNE data booklet available on www.Grundfos.com (WebCAPS).

Grundfos blueflux®

Grundfos blueflux® technology represents the best from Grundfos within energy-efficient motors and frequency converters. Grundfos blueflux® solutions either meet or exceed legislative requirements, such as the EuP IE3 grade.



Fig. 4 Grundfos blueflux® label

Electrical data

MG motor CR, CRI, CRN	
Mounting designation	Up to 4 kW: V18 From 5.5 kW: V1
Insulation class	F
Efficiency class	IE3
Enclosure class	IP55 ¹⁾
Supply voltage	P2: 0.37 to 1.5 kW: 3 x 220-240/380-415 V
Tolerance: - 10/+ 10 %	P2: 2.2 to 5.5 kW: 3 x 380-415 V
	P2: 7.5 to 75 kW: 3 x 380-415/660-690 V
Supply frequency	50 Hz

¹⁾ IP44, IP54 and IP55 are available on request.

Optional motors

The Grundfos standard range of motors covers a wide variety of application demands. However, for special applications or operating conditions, custom-built motor solutions can be provided.

For special applications or operating conditions, we offer custom-built motors such as

- ATEX-approved motors
- MG motors with anti-condensation heating unit
- motors with thermal protection.

Motor protection

MG and Siemens motors

Single-phase Grundfos motors have a built-in thermal overload switch (IEC 34-11: TP 211).

Three-phase motors must be connected to a motor-protective circuit breaker according to local regulations.

Three-phase Grundfos motors as from 3 kW have a built-in thermistor (PTC) according to DIN 44082 (IEC 34-11: TP 211).

TM05 2683 0211

Terminal box positions

As standard, the terminal box is fitted on the suction side of the pump.

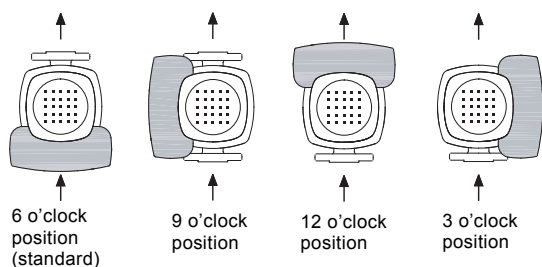

TM03 3658 06 06

Fig. 5 Terminal box positions

Ambient temperature

Motor power [kW]	Motor make	Motor efficiency class	Maximum ambient temperature [°C]	Maximum altitude above sea level [m]
0.37 - 0.55	MG	-	40	1000
0.75 - 22	MG	IE3	60	3500
30 - 75	Siemens	IE3	55	2750

If the ambient temperature exceeds the above maximum temperatures or the pump is installed at an altitude exceeding the above altitude values, the motor must not be fully loaded due to the risk of overheating. Overheating may result from excessive ambient temperatures or the low density and consequently low cooling effect of the air.

In such cases, it may be necessary to use a motor with a higher rated output.

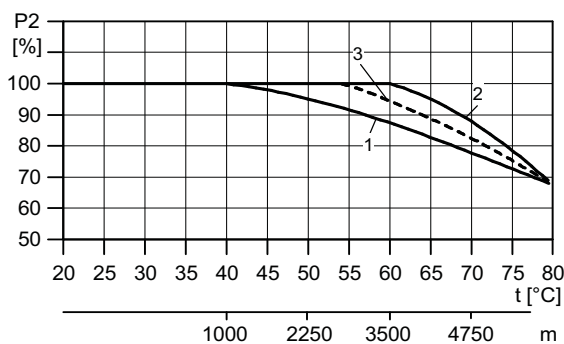

TM03 2479 4 405

Fig. 6 Motor output in relation to temperature/altitude

Pos.	Motor power [kW]	Motor make
1	0.37 and 0.55	MG
2	0.75 to 22	MG
3	30 to 75	Siemens

Viscosity

The pumping of liquids with densities or kinematic viscosities higher than those of water will cause a considerable pressure drop, a drop in the hydraulic performance and a rise in the power consumption.

In such situations, the pump should be fitted with a larger motor. If in doubt, contact Grundfos.

2. Construction

CR 1s, 1, 3, 5, 10, 15 and 20



TM02 1198 0601 - GR7377 - GR7379

Sectional drawing

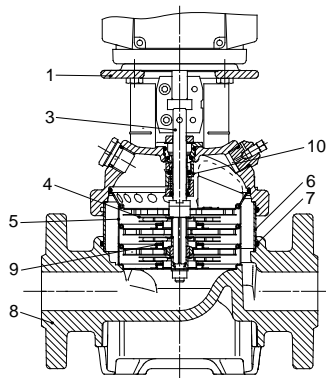

TM02 1194 1403

Materials, CR

Pos.	Designation	Materials	EN/DIN	AISI/ASTM
1	Pump head	Cast iron EN-GJL-200	EN-JL1030	ASTM 25B
3	Shaft	Stainless steel	1.4401 ¹⁾ 1.4057 ²⁾	AISI 316 AISI 431
4	Impeller	Stainless steel	1.4301	AISI 304
5	Chamber	Stainless steel	1.4301	AISI 304
6	Sleeve	Stainless steel	1.4301	AISI 304
7	O-ring for sleeve	EPDM or FKM		
8	Base	Cast iron EN-GJL-200	EN-JL1030	ASTM 25B
9	Neck ring	PTFE		
10	Shaft seal			
	Rubber parts	EPDM or FKM		

- 1) CR 1s, 1, 3, 5.
2) CR 10, 15, 20.

CRI, CRN 1s, 1, 3, 5, 10, 15 and 20



TM02 1808 2001 - GR7373 - GR7375

Sectional drawing

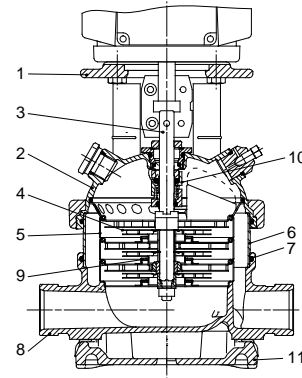

TM02 1195 1403

Materials, CRI and CRN

Pos.	Designation	Materials	EN/DIN	AISI/ASTM
1	Pump head	Cast iron EN-GJL-200 ¹⁾	EN-JL1030	ASTM 25B
2	Pump head cover	Stainless steel	1.4408	CF 8M equal to AISI 316
3	Shaft	Stainless steel	1.4401 ²⁾ 1.4460 ³⁾ 1.4057 ⁴⁾	AISI 316 AISI 329
8	Base	Stainless steel	1.4408	CF 8M equal to AISI 316
9	Neck ring	PTFE		
10	Shaft seal	Cartridge type		
11	Base plate	Cast iron EN-GJL-200 ¹⁾	EN-JL1030	ASTM 25B
	Rubber parts	EPDM or FKM		
CRI				
4	Impeller	Stainless steel	1.4301	AISI 304
5	Chamber	Stainless steel	1.4301	AISI 304
6	Sleeve	Stainless steel	1.4301	AISI 304
7	O-ring for sleeve	EPDM or FKM		
CRN				
4	Impeller	Stainless steel	1.4401	AISI 316
5	Chamber	Stainless steel	1.4401	AISI 316
6	Sleeve	Stainless steel	1.4401	AISI 316
7	O-ring for sleeve	EPDM or FKM		

- 1) Stainless steel available on request.
2) CRI, CRN 1s, 1, 3, 5.
3) CRN 10, 15, 20.
4) CRI 10, 15, 20.

CR 32, 45, 64 and 90



TM01 2150 1298 - GrA4355

Sectional drawing

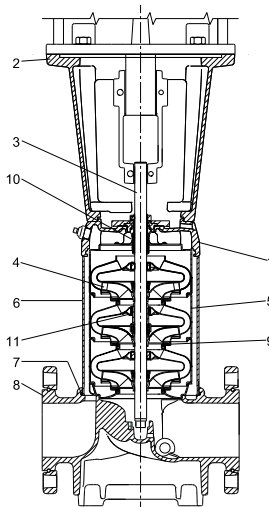

TM05 1836 3713

Materials, CR

Pos.	Designation	Materials	EN/DIN	AISI/ASTM
1	Pump head	Cast iron EN-GJS-500-7	EN-JS1050	ASTM 80-55-06
2	Motor stool	Cast iron EN-GJL-200	EN-JL1030	ASTM 25B
3	Shaft	Stainless steel	1.4057	AISI 431
4	Impeller	Stainless steel	1.4301	AISI 304
5	Chamber	Stainless steel	1.4301	AISI 304
6	Sleeve	Stainless steel	1.4301	AISI 304
7	O-ring for sleeve	EPDM or FKM		
8	Base	Cast iron EN-GJS-500-7	EN-JS1050	ASTM 80-55-06
9	Neck ring	Carbon-graphite-filled PTFE		
10	Shaft seal			
11	Bearing ring	SiC/SiC		
	Bottom bearing ring	Tungsten carbide/tungsten carbide		
	Rubber parts	EPDM or FKM		

CRN 32, 45, 64 and 90



TM02 7399 3403

Sectional drawing

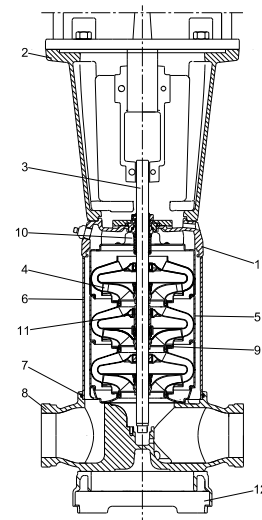

TM05 1837 3713

Materials, CRN

Pos.	Designation	Materials	EN/DIN	AISI/ASTM
1	Pump head	Stainless steel	1.4408	CF 8M equal to AISI 316
2	Motor stool	Cast iron EN-GJL-200 ¹⁾	EN-JL1030	ASTM 25B
3	Shaft	Stainless steel	1.4462	
4	Impeller	Stainless steel	1.4401	AISI 316
5	Chamber	Stainless steel	1.4401	AISI 316
6	Sleeve	Stainless steel	1.4401	AISI 316
7	O-ring for sleeve	EPDM or FKM		
8	Base	Stainless steel	1.4408	CF 8M equal to AISI 316
9	Neck ring	Carbon-graphite-filled PTFE		
10	Shaft seal			
11	Bearing ring	SiC/SiC		
12	Base plate	Cast iron EN-GJS-500-7 ¹⁾	EN-JS1050	ASTM 88-55-06
	Bottom bearing ring	Tungsten carbide/tungsten carbide		
	Rubber parts	EPDM or FKM		

¹⁾ Stainless steel available on request.

CR 120 and 150



GRA3731

Sectional drawing

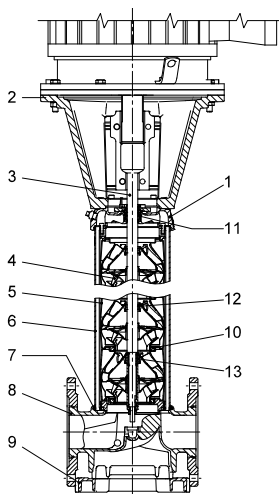

TMD3 8835 2607

Materials, CR

Pos.	Designation	Materials	EN/DIN	AISI/ASTM
1	Pump head	Cast iron EN-GJS-500-7	EN-JS1050	A 536 65-45-12
2	Motor stool (11-45 kW)	Cast iron EN-GJL-200	EN-JL1030	A48-30 B
	Motor stool (55-75 kW)	Cast iron EN-GJS-500-7	EN-JS1050	A 536 65-45-12
3	Shaft	Stainless steel	1.4057	AISI 431
4	Impeller	Stainless steel	1.4301	AISI 304
5	Chamber	Stainless steel	1.4301	AISI 304
6	Sleeve	Stainless steel	1.4401	AISI 316
7	O-ring for sleeve	EPDM or FKM		
8	Base	Cast iron EN-GJS-500-7	EN-JS1050	A 536 65-45-12
9	Base plate	Cast iron EN-GJS-500-7	EN-JS1050	A 536 65-45-12
10	Neck ring	PTFE		
11	Shaft seal ¹⁾	SiC/SiC (∅22) Carbon/SiC (∅32)		
12	Support bearing	PTFE		
13	Bearing ring	SiC/SiC		
	Rubber parts	EPDM or FKM		

¹⁾ ∅22 mm shaft, 11-45 kW.
∅32 mm shaft, 55-75 kW.

CRN 120 and 150



GRA3732 - GRA3735

Sectional drawing

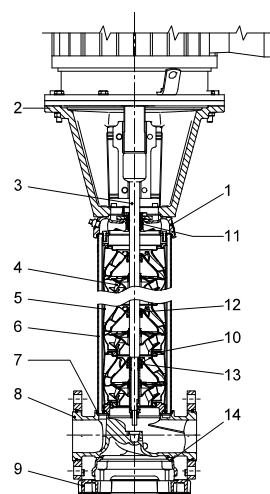

TMD3 8836 2607

Materials, CRN

Pos.	Designation	Materials	EN/DIN	AISI/ASTM
1	Pump head	Stainless steel	1.4408	A 351 CF 8M
2	Motor stool (11-45 kW)	Cast iron EN-GJL-200	EN-JL1030	A48-30 B
	Motor stool (55-75 kW)	Cast iron EN-GJS-500-7	EN-JS1050	A 536 65-45-12
3	Shaft	Stainless steel	1.4462	SAF 2205
4	Impeller	Stainless steel	1.4401	AISI 316
5	Chamber	Stainless steel	1.4401	AISI 316
6	Sleeve	Stainless steel	1.4401	AISI 316
7	O-ring for sleeve	EPDM or FKM		
8	Base	Stainless steel	1.4408	A 351 CF 8M
9	Base plate	Cast iron EN-GJS-500-7 ¹⁾	EN-JS1050	A 536 65-45-12
10	Neck ring	PTFE		
11	Shaft seal ²⁾	SiC/SiC (∅22) Carbon/SiC (∅32)		
12	Support bearing	PTFE		
13	Bearing ring	SiC/SiC		
14	Base plate	Cast iron EN-GJS-500-7 ¹⁾	EN-JS1050	A 536 65-45-12
	Rubber parts	EPDM or FKM		

¹⁾ Stainless steel available on request.

²⁾ ∅22 mm shaft, 11-45 kW.
∅32 mm shaft, 55-75 kW.

Type keys

CR, CRI, CRN

Example	CR 32 (s) -4 -2 -A -F -G -E -HQQE
Type range: CR, CRI, CRN	
Flow rate [m ³ /h]	
All impellers with reduced diameter (applies only to CR, CRI, CRN 1s)	
Number of impellers	
Number of reduced-diameter impellers (CR, CRN 32, 45, 64, 90, 120, 150)	
Code for pump version	
Code for pipe connection	
Code for materials	
Code for rubber parts	
Code for shaft seal	

Codes

Example	A	-F	-A	-E	-H	QQ	E
Pump version							
A	Basic version						
B	Oversize motor						
E	Pump with certificate/approval and ATEX-approved pumps						
F	CR pump for high temperatures (air-cooled top assembly)						
H	Horizontal version						
I	Different pressure rating						
J	Pump w/different max. speed						
K	Pump with low NPSH						
M	Magnetic drive						
N	Fitted with sensor						
P	Undersize motor						
R	Horizontal version with bearing bracket						
SF	High-pressure pump						
X	Special version						
Pipe connection							
A	Oval flange						
B	NPT thread						
CA	FlexiClamp (CRI, CRN 1s, 1, 3, 5, 10, 15, 20)						
F	DIN flange						
G	ANSI flange						
J	JIS flange						
N	Changed diameter of ports						
P	PJE coupling						
X	Special version						
Materials							
A	Basic version						
AD	Carbon-graphite-filled PTFE (bearings)						
G	Wetted parts of 1.4401/AISI 316						
GI	All parts of stainless steel, wetted parts of 1.4401/AISI 316						
I	Wetted parts of 1.4301/AISI 304						
II	All parts of stainless steel, wetted parts of 1.4301/AISI 304						
K	Bronze (bearings)						
S	SiC bearings + PTFE neck rings						
X	Special version						
Code for rubber parts							
E	EPDM						
F	FXM						
K	FFKM						
V	FKM						
Shaft seal							
H	Balanced cartridge seal						
Q	Silicon carbide						
U	Tungsten carbide						
B	Carbon						
E	EPDM						
F	FXM						
K	FFKM						
V	FKM						

3. Operating and inlet pressures

Maximum operating pressure and liquid temperature

Pump type	Oval flange		PJE, clamp, union, DIN	
	Maximum permissible operating pressure [bar]	Liquid temperature [°C]	Maximum permissible operating pressure [bar]	Liquid temperature [°C]
	16	-20 - +120	25	-20 - +120
CR, CRI, CRN 1s	16		25	
CR, CRI, CRN 1	16		25	
CR, CRI, CRN 3	16	-20 - +120	25	
CR, CRI, CRN 5	16	-	25	
CR, CRI 10-1 → 10-16	16	-	16	
CR, CRI 10-17 → 10-22	-	-	25	
CRN 10	-	-	25	
CR, CRI 15-1 → 15-7	10	-20 - +120	-	-
CR, CRI 15-1 → 15-10	-	-	16	-20 - +120
CR, CRI 15-12 → 15-17	-	-	25	
CRN 15	-	-	25	
CR, CRI 20-1 → 20-7	10	-20 - +120	-	-
CR, CRI 20-1 → 20-10	-	-	16	-20 - +120
CR, CRI 20-12 → 20-17	-	-	25	
CRN 20	-	-	25	
CR, CRN 32-1-1 → 32-7	-	-	16	
CR, CRN 32-8-2 → 32-14	-	-	30	-30 - +120
CR, CRN 45-1-1 → 45-5	-	-	16	
CR, CRN 45-6-2 → 45-11	-	-	30	
CR, CRN 45-12-2 → 45-13-2	-	-	33	
CR, CRN 64-1-1 → 64-5	-	-	16	
CR, CRN 64-6-2 → 64-8-1	-	-	30	
CR, CRN 90-1-1 → 90-4	-	-	16	
CR, CRN 90-5-2 → 90-6	-	-	30	
CR, CRN 120	-	-	30	
CR, CRN 150	-	-	30	

For pump sizes 32, 45, 64, 90, 120, 150, the max. pressure for PJE is 50 bar and only available in CRN version.

Operating range of the shaft seal

The operating range of the shaft seal depends on operating pressure, pump type, type of shaft seal and liquid temperature. The range shown in fig. 7 applies to clean water and water with anti-freeze liquids.

For selection of the right shaft seal, see section 7. *Pumped liquids*, page 75. If the operating range is exceeded, the life of the shaft seal may be reduced.

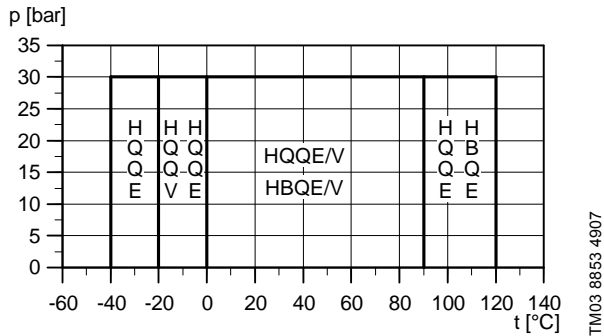

Fig. 7 Operating range of standard shaft seals

Standard shaft seal	Motor size [kW]	Description	Liquid temperature [°C]
HQQE	0.37 - 45	O-ring (cartridge) (balanced seal), SiC/SiC, EPDM	-40 - +120
HBQE ¹⁾	55 - 75	O-ring (cartridge) (balanced seal), carbon/SiC, EPDM	0-120
HQQV	0.37 - 45	O-ring (cartridge) (balanced seal), SiC/SiC, FKM	-20 - +90
HBQV ¹⁾	55 - 75	O-ring (cartridge) (balanced seal), carbon/SiC, FKM	0-90

¹⁾ Available as HQQE and HQQV on request.

See section 9. *Variants*, page 86, in case of extreme temperatures:

- low temperatures down to -40 °C
- high temperatures up to +180 °C.

Maximum inlet pressure

The following table shows the maximum permissible inlet pressure. However, the actual inlet pressure plus the pressure against a closed valve must always be lower than the maximum permissible operating pressure.

If the maximum permissible operating pressure is exceeded, the conical bearing in the motor may be damaged and the life of the shaft seal reduced.

Pump type	Maximum inlet pressure [bar]
CR, CRI, CRN 1s	
1s-2 → 1s-36	10
CR, CRI, CRN 1	
1-2 → 1-36	10
CR, CRI, CRN 3	
3-2 → 3-29	10
3-31 → 3-36	15
CR, CRI, CRN 5	
5-2 → 5-16	10
5-18 → 5-36	15
CR, CRI, CRN 10	
10-1 → 10-6	8
10-7 → 10-22	10
CR, CRI, CRN 15	
15-1 → 15-3	8
15-4 → 15-17	10
CR, CRI, CRN 20	
20-1 → 20-3	8
20-4 → 20-17	10
CR, CRN 32	
32-1-1 → 32-4	4
32-5-2 → 32-10	10
32-11-2 → 32-14	15
CR, CRN 45	
45-1-1 → 45-2	4
45-3-2 → 45-5	10
45-6-2 → 45-13-2	15
CR, CRN 64	
64-1-1 → 64-2-2	4
64-2-1 → 64-4-2	10
64-4-1 → 64-8-1	15
CR, CRN 90	
90-1-1 → 90-1	4
90-2-2 → 90-3-2	10
90-3 → 90-6	15
CR, CRN 120	
120-1 → 120-2-1	10
120-2 → 120-5-1	15
120-6-1 → 120-7	20
CR, CRN 150	
150-1-1 → 150-1	10
150-2-1 → 150-4-1	15
150-5-2 → 150-6	20

Examples of operating and inlet pressures

The values for operating and inlet pressures shown in the table should not be considered individually but should always be compared. See the following examples.

Example 1

The following pump type has been selected:
CR 5-16 A-A-A.

Maximum operating pressure: 16 bar.

Maximum inlet pressure: 10 bar.

Discharge pressure against a closed valve: 10.6 bar.

See page 35.

This pump is **not** allowed to start at an inlet pressure of 10 bar, but at an inlet pressure of $16.0 - 10.6 = 5.4$ bar.

Example 2

The following pump type has been selected:

CR 10-2 A-A-A.

Maximum operating pressure: 16 bar.

Maximum inlet pressure: 8.0 bar.

Discharge pressure against a closed valve: 2 bar.

See page 39.

This pump **is** allowed to start at an inlet pressure of 8.0 bar, as the discharge pressure against a closed valve is 2.0 bar. This results in an operating pressure of $8.0 + 2.0 = 10.0$ bar. On the contrary, the maximum operating pressure of this pump is limited to 16.0 bar as a higher operating pressure will require an inlet pressure of more than $14.0 \text{ bar} > 8.0 \text{ bar}$.

If the inlet or operating pressure exceeds the pressure permitted, see section 9. *Variants*, page 86.

4. Selection and sizing

Selection of pumps

Selection of pumps should be based on these parameters:

- the duty point of the pump (see below)
- dimensional data such as pressure loss as a result of height differences, friction loss in the pipework, pump efficiency (see below)
- pump materials (see page 19)
- pump connections (see page 19)
- shaft seal (see page 19).

Duty point of the pump

From a duty point, it is possible to select a pump on the basis of the curve charts in section 5. *Performance curves and technical data*, page 22.

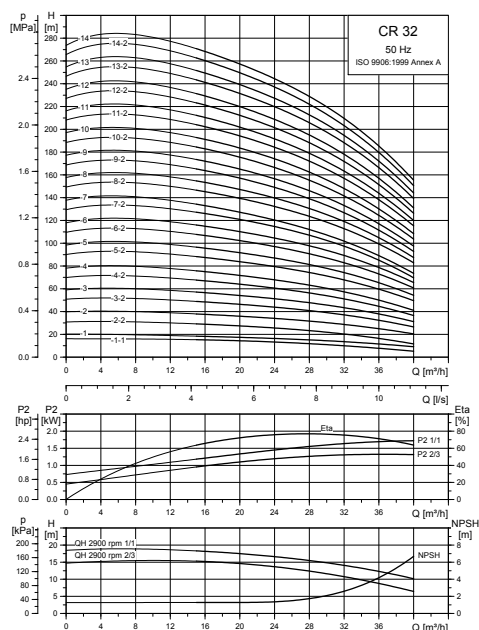

Fig. 8 Example of a curve chart

Dimensional data

When sizing a pump, take these parameters into account:

- Required flow and pressure at the draw-off point.
- Pressure loss as a result of height differences (H_{geo}).
- Friction loss in the pipework (H_f). It may be necessary to account for pressure loss in connection with long pipes, bends or valves, etc.
- Best efficiency at the estimated duty point.
- NPSH value. For calculation of the NPSH value, see *Minimum inlet pressure, NPSH*, page 20.

Pump efficiency

Before determining the best efficiency point, identify the operation pattern of the pump. If the pump is expected to operate at the same duty point, select a CR pump which is operating at a duty point corresponding to the best efficiency of the pump.

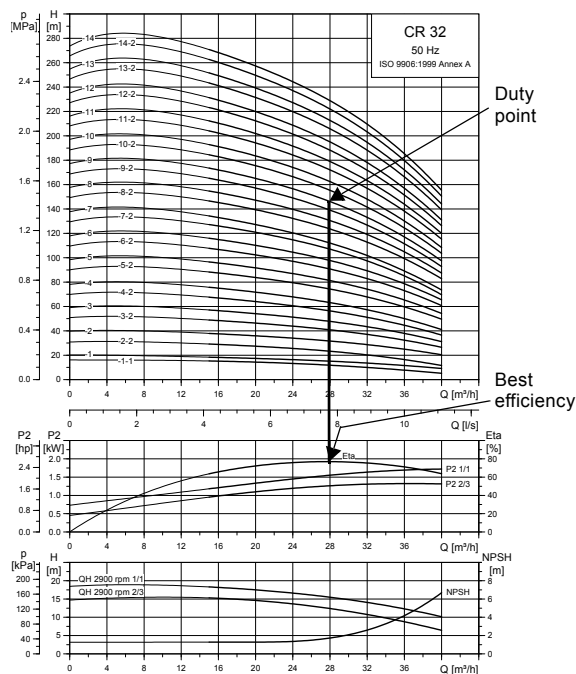

Fig. 9 Example of a CR pump's duty point

As the pump is sized on the basis of the highest possible flow, it is important always to have the duty point to the right on the efficiency curve (eta) in order to keep the efficiency high when the flow drops.

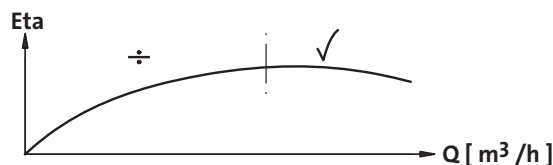

Fig. 10 Best efficiency

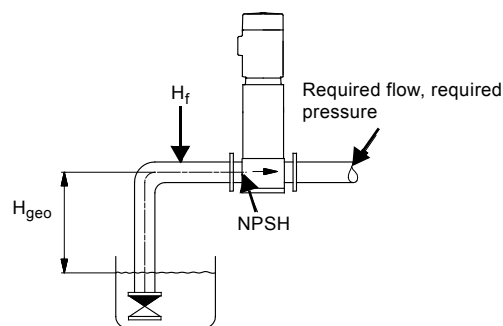

Fig. 11 Dimensional data

Pump material

Select the material variant on the basis of the liquid to be pumped.

The product range covers the following three basic types.

- CR, CRI
Use CR, CRI pumps for clean, non-aggressive liquids, such as potable water and oils.
- CRN
Use CRN pumps for industrial liquids and acids. See *List of pumped liquids*, page 75, or contact Grundfos.

For saline or chloride-containing liquids such as sea water, CRT pumps of titanium are available.

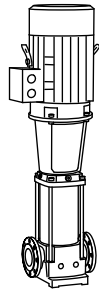

TM01 2100 1198

Fig. 12 CR pump

Pump connections

Selection of pump connection depends on the rated pressure and pipework. To meet any requirement, the CR, CRI and CRN pumps offer a wide range of flexible connections, such as

- oval flange (BSP)
- DIN flange
- PJE coupling
- clamp coupling
- union (+GF+)
- other connections on request.

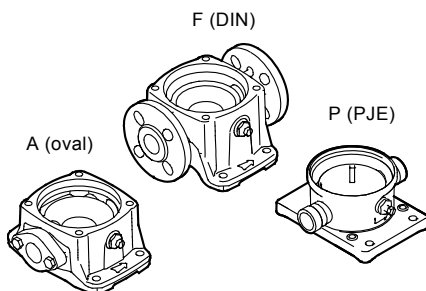

TM02 1201 0601

Fig. 13 Pump connections

Shaft seal

As standard, the CR range is fitted with a Grundfos shaft seal (cartridge type) suitable for the most common applications.

These key parameters must be taken into account when selecting the shaft seal:

- type of pumped liquid
- liquid temperature
- maximum pressure.

We offer a wide range of shaft seal variants to meet specific demands. See section 7. *Pumped liquids*, page 75.

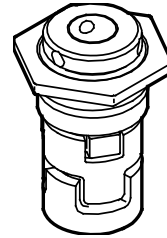

TM02 0538 4800

Fig. 14 Shaft seal (cartridge type)

Operating pressure and inlet pressure

Do not exceed the limit values for these pressures:

- maximum operating pressure (page 15)
- maximum inlet pressure (page 17).

Minimum inlet pressure, NPSH

Calculation of the inlet pressure "H" is recommended in these situations:

- The liquid temperature is high.
- The flow is significantly higher than the rated flow.
- Water is drawn from depths.
- Water is drawn through long pipes.
- Inlet conditions are poor.

To avoid cavitation, make sure that there is a minimum pressure on the suction side of the pump.

The maximum suction lift "H" in metres head can be calculated as follows:

$$H = p_b \times 10.2 - \text{NPSH} - H_f - H_v - H_s$$

p_b	= Barometric pressure in bar. Barometric pressure can be set to 1 bar. In closed systems, p_b indicates the system pressure in bar.
NPSH	= Net Positive Suction Head in metres head. To be read from the NPSH curve at the highest flow the pump will be delivering.
H_f	= Friction loss in suction pipe in metres head. At the highest flow the pump will be delivering.
H_v	= Vapour pressure in metres head. To be read from the vapour pressure scale. H_v depends on the liquid temperature t_m .
H_s	= Safety margin = minimum 0.5 metres head.

If the calculated "H" is positive, the pump can operate at a suction lift of maximum "H" metres head.

If the calculated "H" is negative, an inlet pressure of minimum "H" metres head is required.

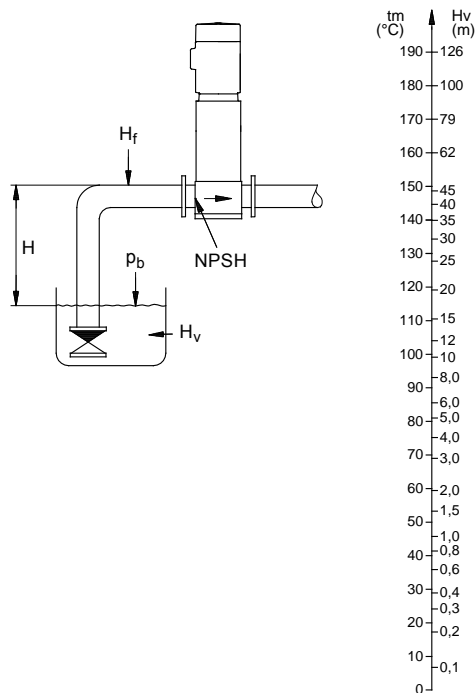

TM02 7439 3403

Fig. 15 Minimum inlet pressure, NPSH

Note: To avoid cavitation, do not select a pump with a duty point too far to the right on the NPSH curve.

Always check the NPSH value of the pump at the highest possible flow.

How to read the curve charts

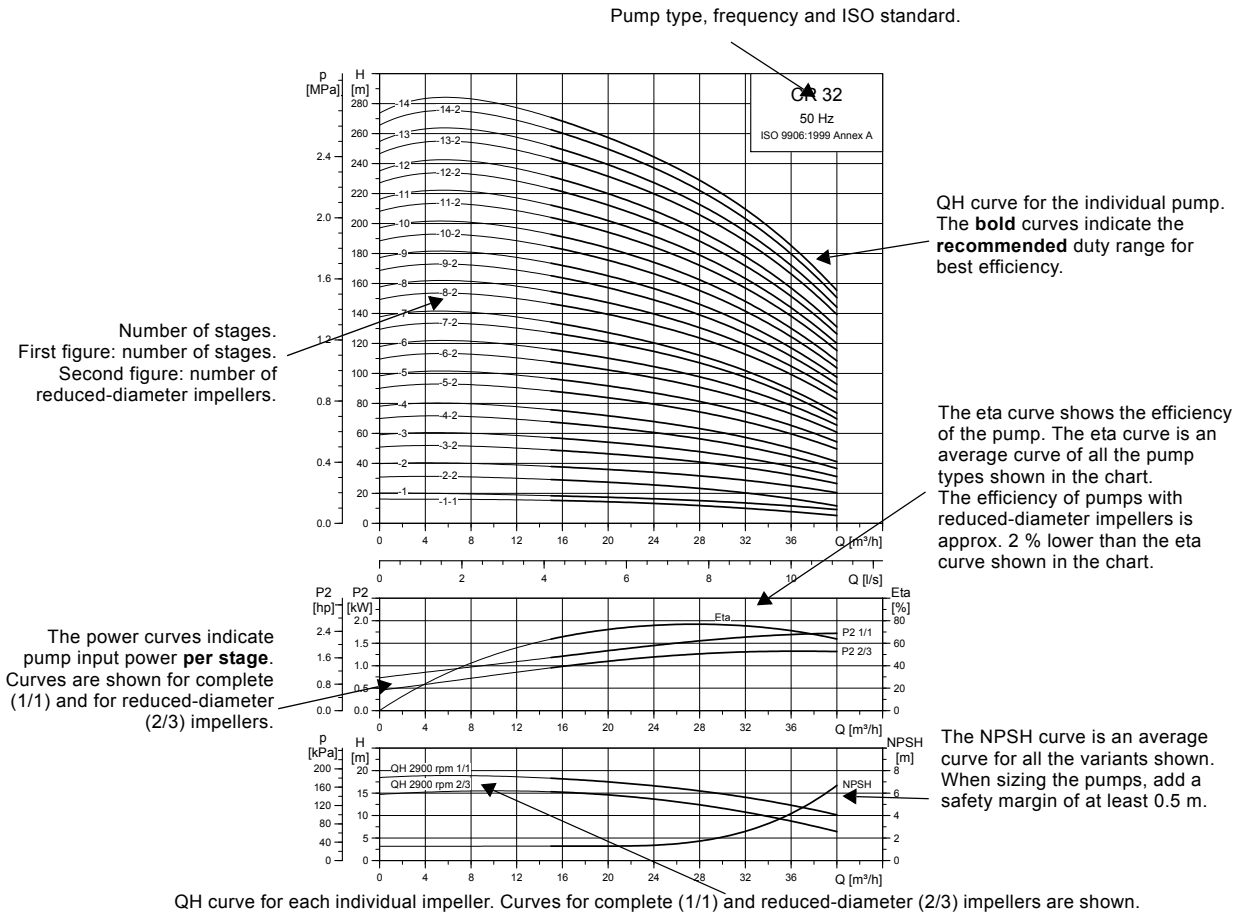

QH curve for each individual impeller. Curves for complete (1/1) and reduced-diameter (2/3) impellers are shown.

Fig. 16 How to read the curve charts

Guidelines to performance curves

The guidelines below apply to the curves shown on the following pages:

- Tolerances to ISO 9906:1999, Annex A, if indicated.
- The motors used for the measurements are standard Grundfos MG motors.
- Measurements have been made with airless water at a temperature of 20 °C.
- The curves apply to the following kinematic viscosity: $\nu = 1 \text{ mm}^2/\text{s}$ (1 cSt).
- Due to the risk of overheating, the pumps should not be used at a flow below the minimum flow rate.
- The QH curves apply to a rated motor speed of a three-phase mains-operated motor.

The curve below shows the minimum flow rate as a percentage of the rated flow rate in relation to the liquid temperature. The dotted line shows a CR pump fitted with an air-cooled top assembly.

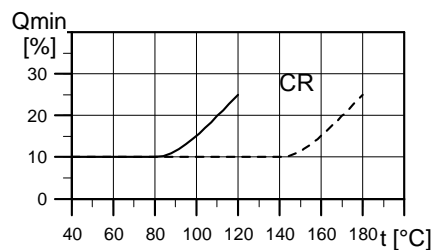

Fig. 17 Minimum flow rate

TM02 7302 3103

TM01 2816 0303

5. Performance curves and technical data

CR 1s

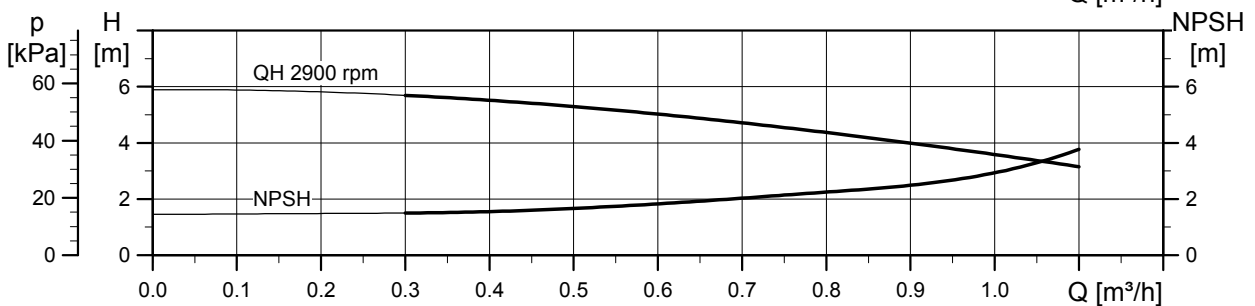
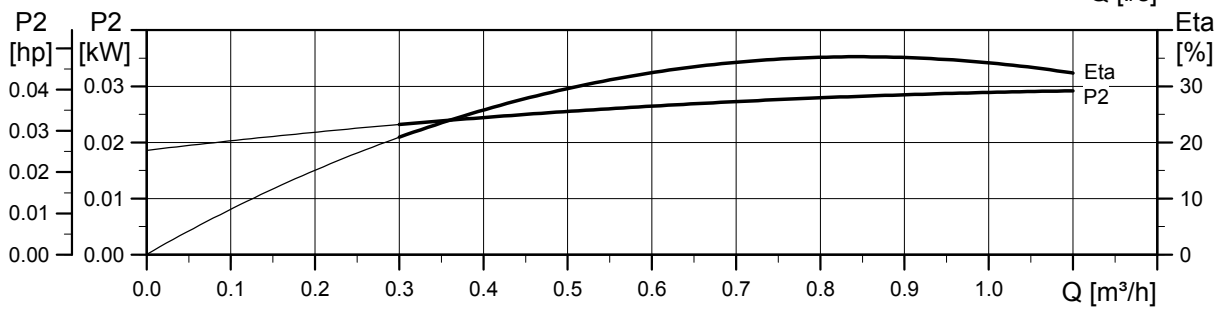
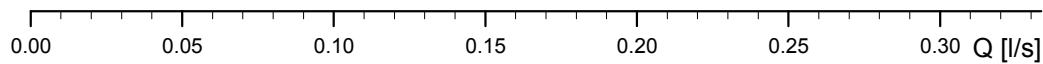
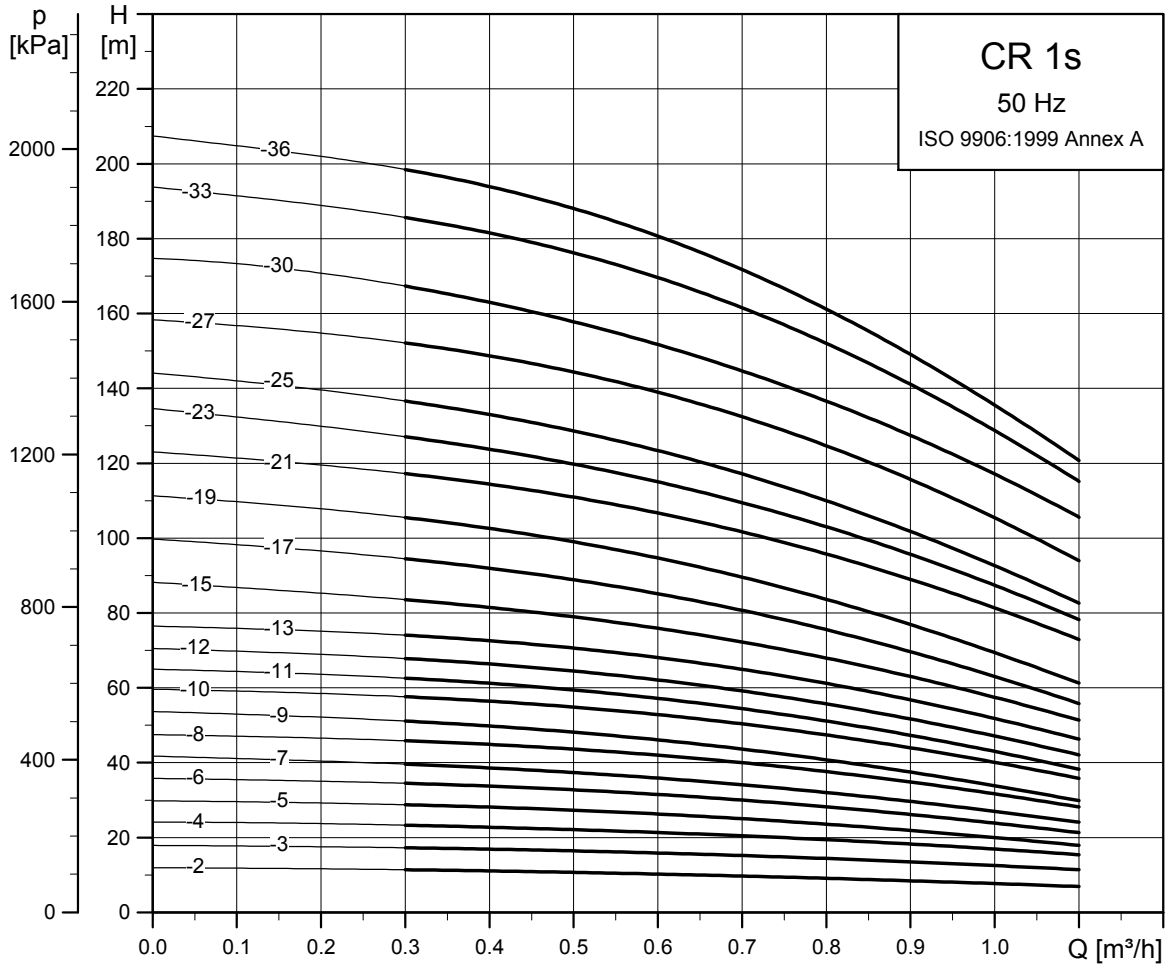

TM02 7424 1013

Dimensional sketch

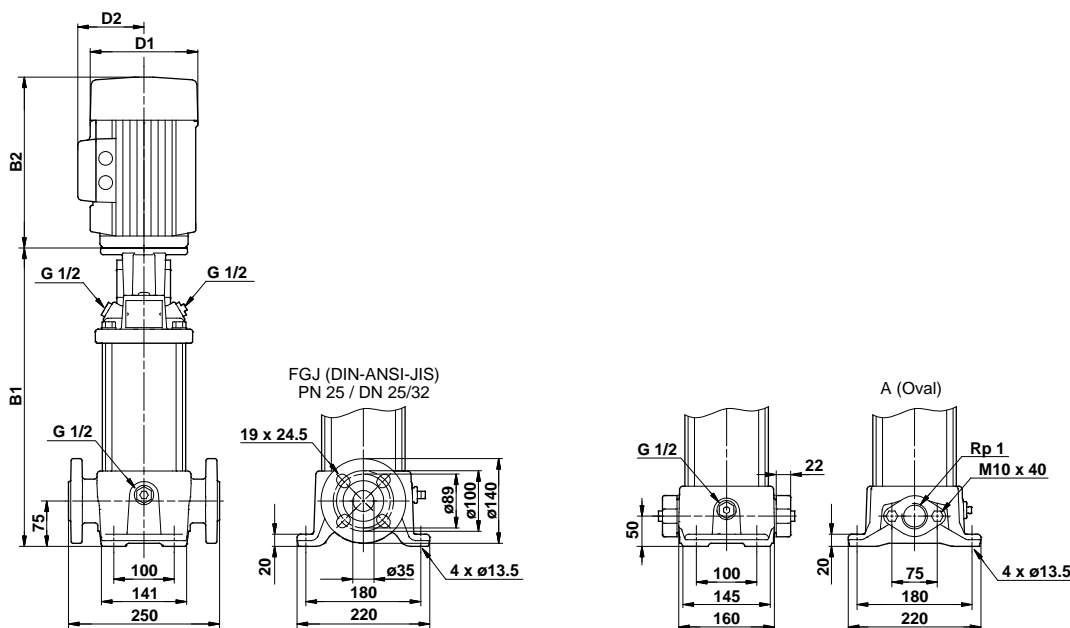

Dimensions and weights

Pump type	Motor P ₂ [kW]	Dimension [mm]						Net weight [kg]	
		Oval flange		DIN flange		D1	D2	Oval flange	DIN flange
		B1	B1+B2	B1	B1+B2				
CR 1s-2	0.37	254	445	279	470	141	109	18	23
CR 1s-3	0.37	254	445	279	470	141	109	18	23
CR 1s-4	0.37	272	463	297	488	141	109	19	23
CR 1s-5	0.37	290	481	315	506	141	109	19	24
CR 1s-6	0.37	308	499	333	524	141	109	19	24
CR 1s-7	0.37	326	517	351	542	141	109	20	24
CR 1s-8	0.37	344	535	369	560	141	109	20	25
CR 1s-9	0.37	362	553	387	578	141	109	21	25
CR 1s-10	0.37	380	571	405	596	141	109	21	26
CR 1s-11	0.37	398	589	423	614	141	109	21	26
CR 1s-12	0.37	416	607	441	632	141	109	22	26
CR 1s-13	0.37	434	625	459	650	141	109	22	27
CR 1s-15	0.55	470	661	495	686	141	109	24	28
CR 1s-17	0.55	506	697	531	722	141	109	25	29
CR 1s-19	0.55	542	733	567	758	141	109	25	30
CR 1s-21	0.75	584	815	609	840	141	109	28	32
CR 1s-23	0.75	620	851	645	876	141	109	29	33
CR 1s-25	0.75	656	887	681	912	141	109	29	34
CR 1s-27	1.10	692	943	717	968	141	109	32	37
CR 1s-30	1.10	-	-	771	1022	141	109	-	38
CR 1s-33	1.10	-	-	825	1076	141	109	-	39
CR 1s-36	1.10	-	-	879	1130	141	109	-	41

TM03 1721 2805

CRI, CRN 1s

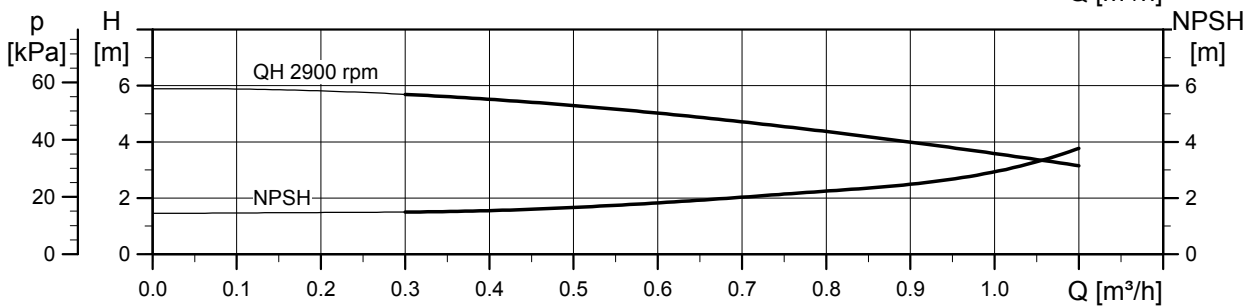
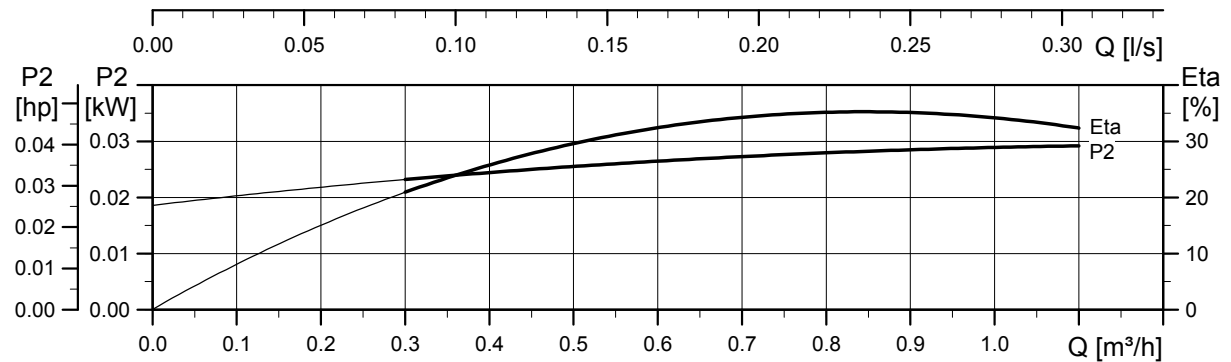
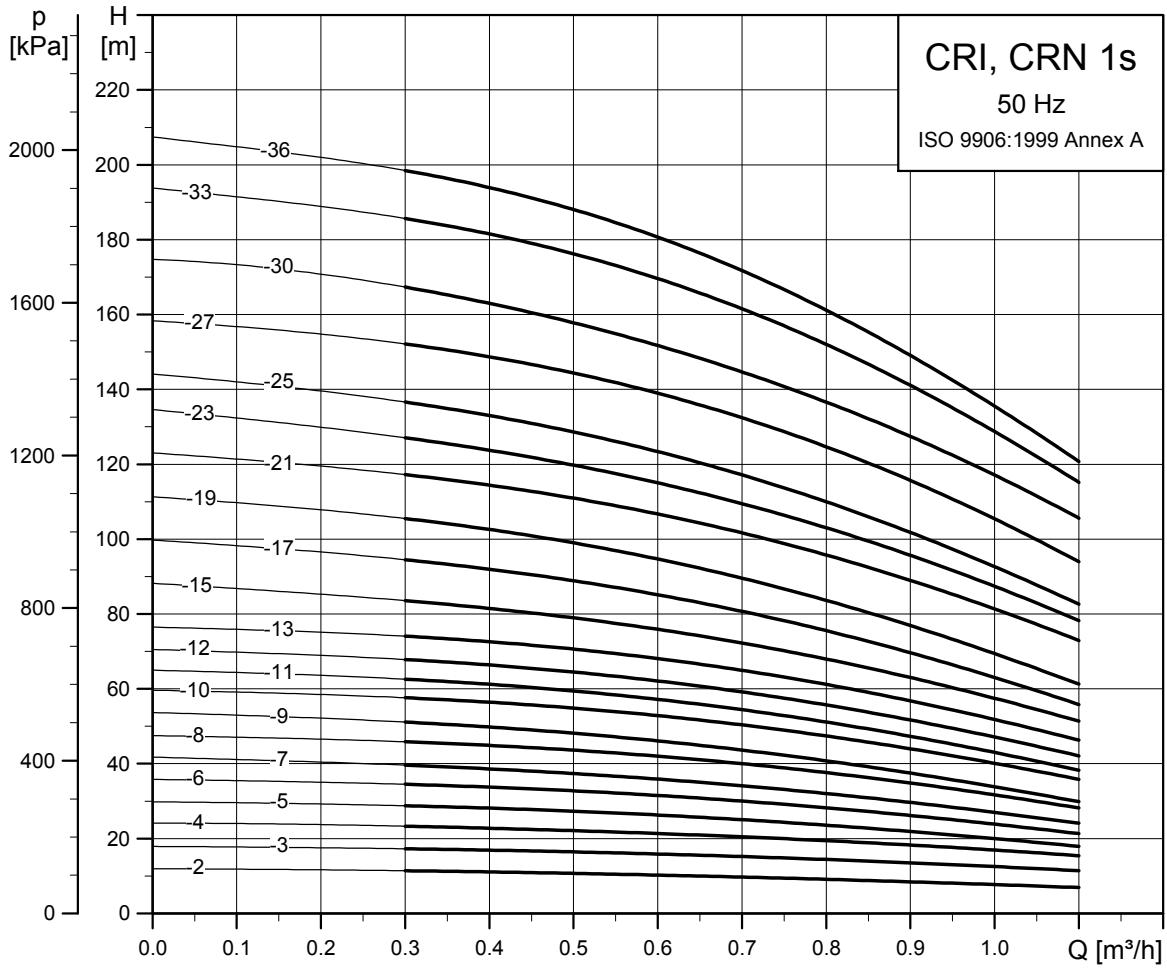

TM02 7425 1013

Dimensional sketch

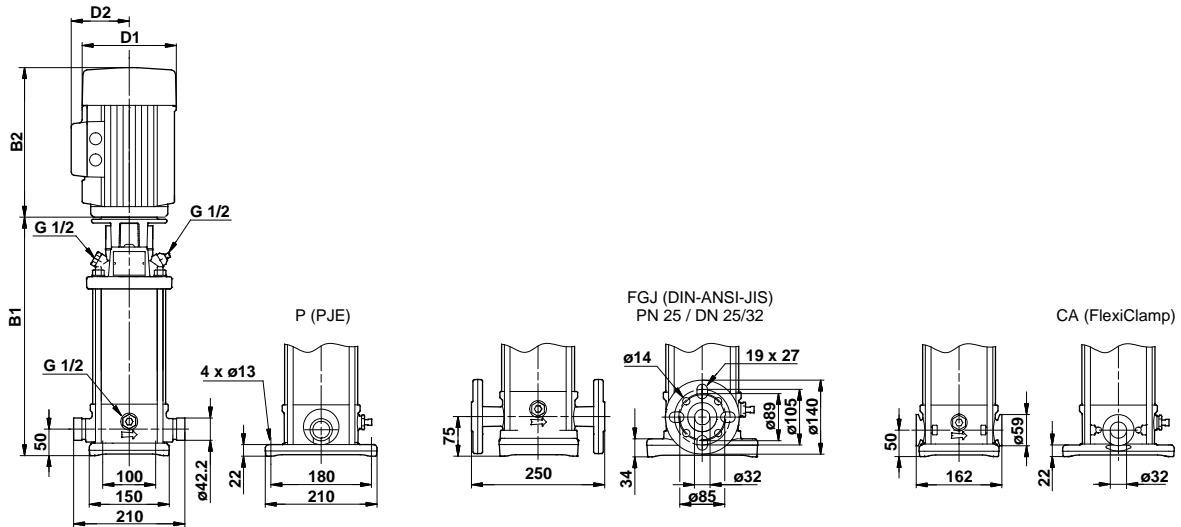

TM03 1722 2805

Dimensions and weights

Pump type	Motor P ₂ [kW]	Dimension [mm]						Net weight [kg]	
		PJE/CA		DIN flange		D1	D2	PJE/CA	DIN flange
		B1	B1+B2	B1	B1+B2				
CRI/CRN 1s-2	0.37	257	448	282	473	141	109	16	20
CRI/CRN 1s-3	0.37	257	448	282	473	141	109	16	21
CRI/CRN 1s-4	0.37	275	466	300	491	141	109	17	21
CRI/CRN 1s-5	0.37	293	484	318	509	141	109	17	21
CRI/CRN 1s-6	0.37	311	502	336	527	141	109	18	22
CRI/CRN 1s-7	0.37	329	520	354	545	141	109	18	22
CRI/CRN 1s-8	0.37	347	538	372	563	141	109	18	23
CRI/CRN 1s-9	0.37	365	556	390	581	141	109	19	23
CRI/CRN 1s-10	0.37	383	574	408	599	141	109	19	23
CRI/CRN 1s-11	0.37	401	592	426	617	141	109	20	24
CRI/CRN 1s-12	0.37	419	610	444	635	141	109	20	24
CRI/CRN 1s-13	0.37	437	628	462	653	141	109	20	25
CRI/CRN 1s-15	0.55	473	664	498	689	141	109	22	26
CRI/CRN 1s-17	0.55	509	700	534	725	141	109	23	27
CRI/CRN 1s-19	0.55	545	736	570	761	141	109	23	28
CRI/CRN 1s-21	0.75	587	818	612	843	141	109	26	31
CRI/CRN 1s-23	0.75	623	854	648	879	141	109	27	31
CRI/CRN 1s-25	0.75	659	890	684	915	141	109	28	32
CRI/CRN 1s-27	1.10	695	946	720	971	141	109	31	35
CRI/CRN 1s-30	1.10	749	1000	774	1025	141	109	32	36
CRI/CRN 1s-33	1.10	803	1054	828	1079	141	109	33	38
CRI/CRN 1s-36	1.10	857	1108	882	1133	141	109	35	39

CR 1

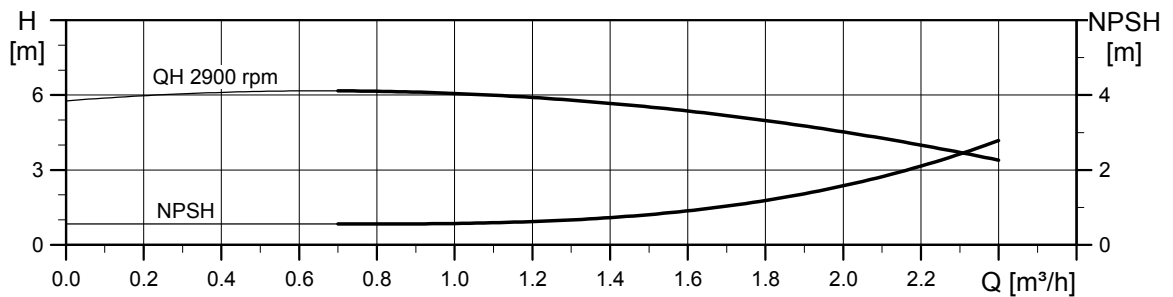
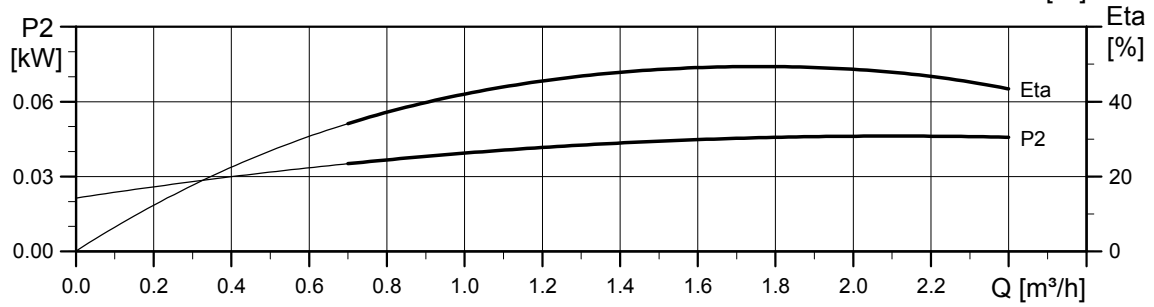
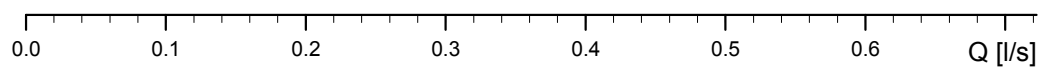
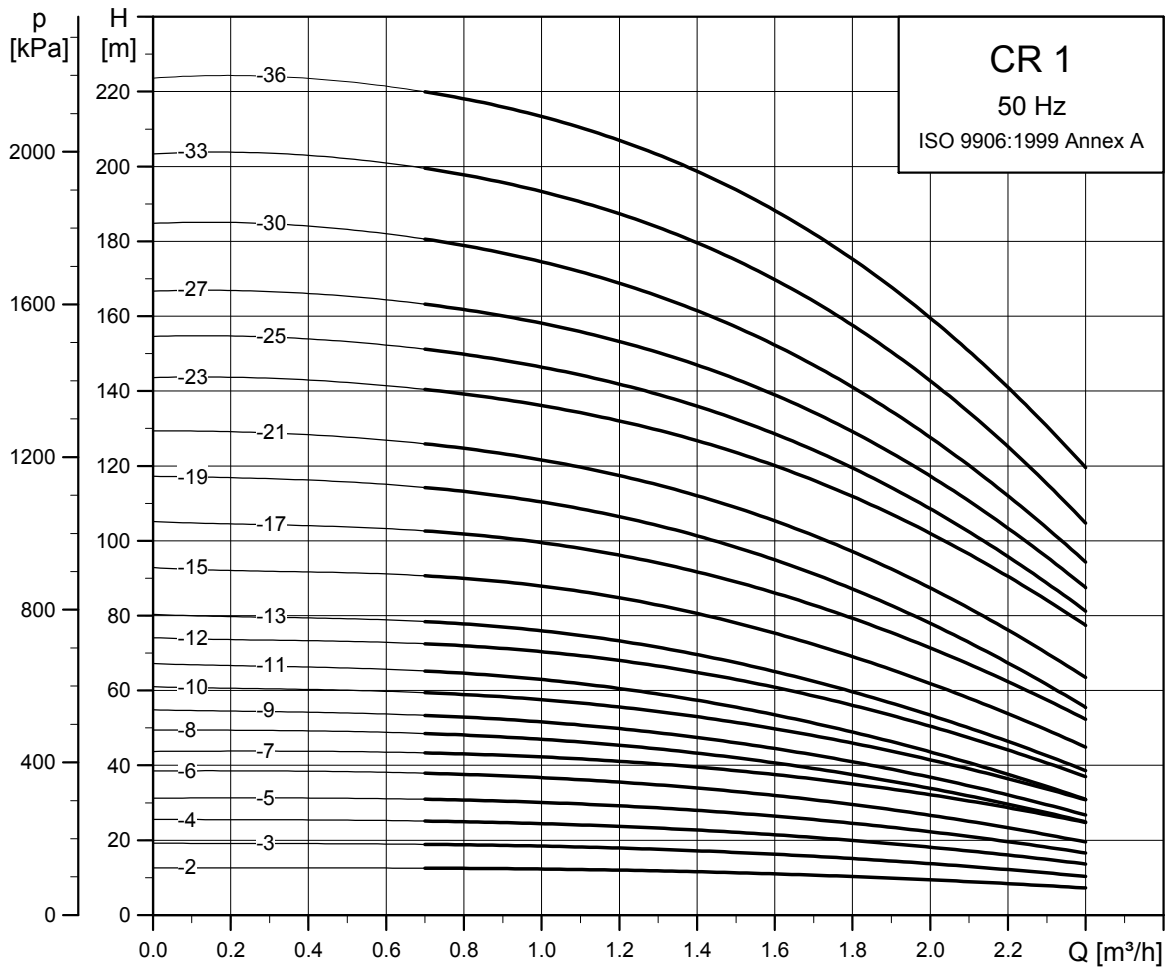

TM02 7290 1013

Dimensional sketch

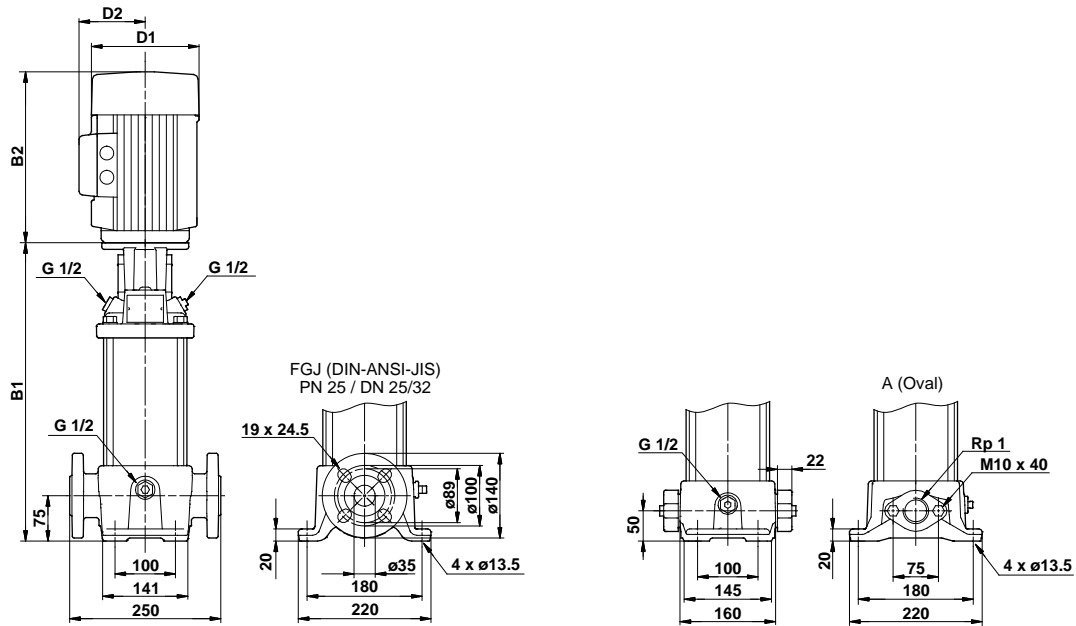

TM03 1721 2805

Dimensions and weights

Pump type	Motor P ₂ [kW]	CR							
		Dimension [mm]						Net weight [kg]	
		Oval flange		DIN flange		D1	D2	Oval flange	DIN flange
		B1	B1+B2	B1	B1+B2				
CR 1-2	0.37	254	445	279	470	141	109	18	23
CR 1-3	0.37	254	445	279	470	141	109	18	23
CR 1-4	0.37	272	463	297	488	141	109	19	23
CR 1-5	0.37	290	481	315	506	141	109	19	24
CR 1-6	0.37	308	499	333	524	141	109	20	24
CR 1-7	0.37	326	517	351	542	141	109	20	25
CR 1-8	0.55	344	535	369	560	141	109	21	26
CR 1-9	0.55	362	553	387	578	141	109	21	26
CR 1-10	0.55	380	571	405	596	141	109	22	26
CR 1-11	0.55	398	589	423	614	141	109	22	27
CR 1-12	0.75	422	653	447	678	141	109	24	29
CR 1-13	0.75	440	671	465	696	141	109	25	29
CR 1-15	0.75	476	707	501	732	141	109	26	30
CR 1-17	1.10	512	763	537	788	141	109	29	33
CR 1-19	1.10	548	799	573	824	141	109	30	34
CR 1-21	1.10	584	835	609	860	141	109	30	35
CR 1-23	1.10	620	871	645	896	141	109	31	36
CR 1-25	1.50	-	-	697	978	178	110	-	44
CR 1-27	1.50	-	-	733	1014	178	110	-	44
CR 1-30	1.50	-	-	787	1068	178	110	-	46
CR 1-33	2.20	-	-	841	1162	178	110	-	47
CR 1-36	2.20	-	-	895	1216	178	110	-	49

CRI, CRN 1

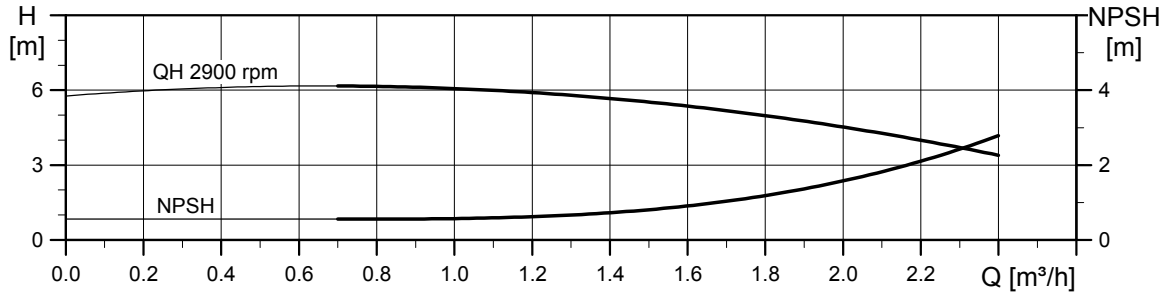
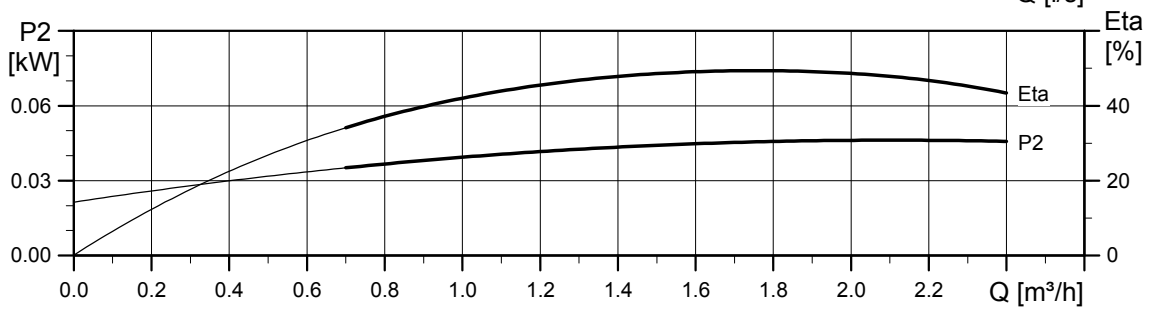
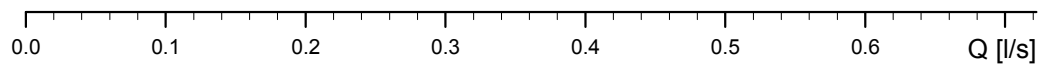
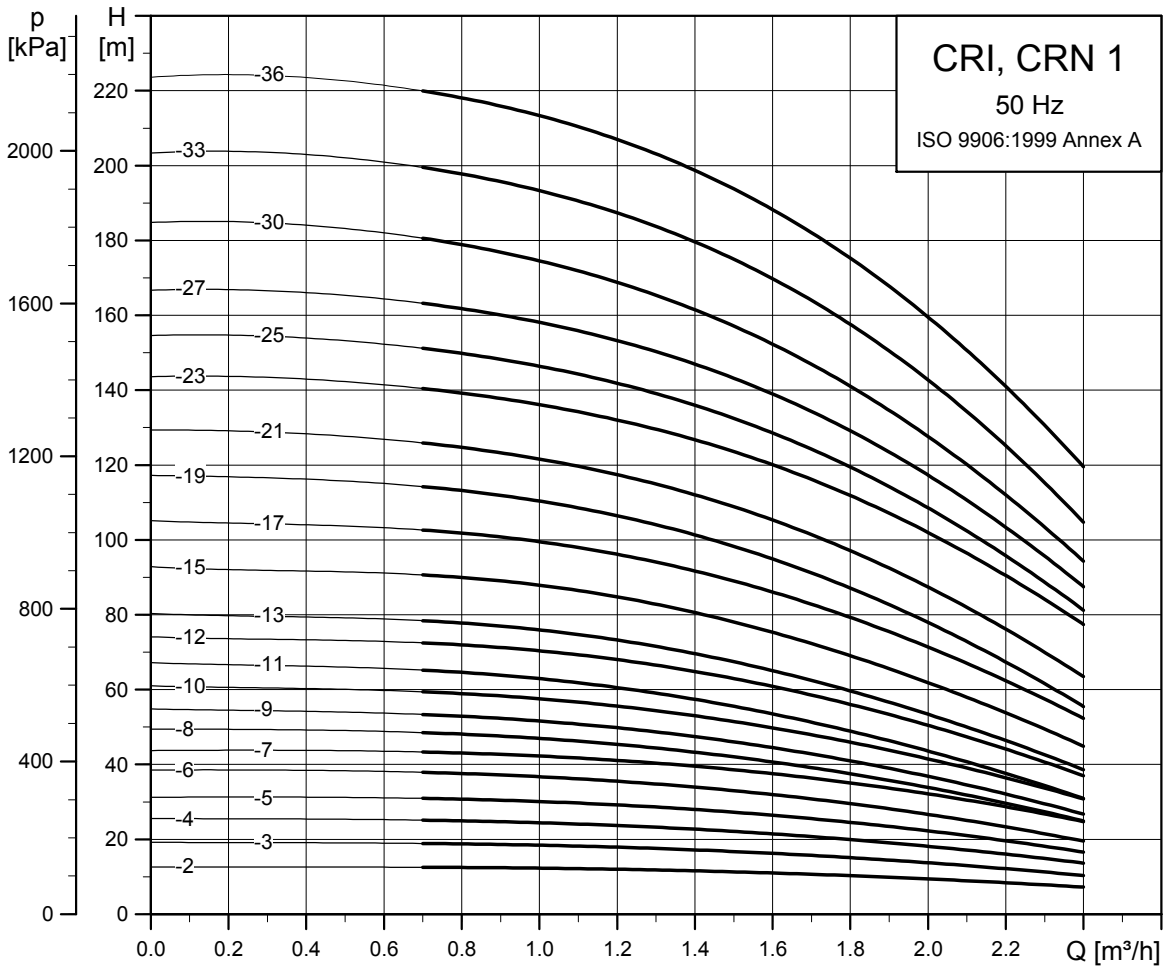

TM02 7291 1013

Dimensional sketch

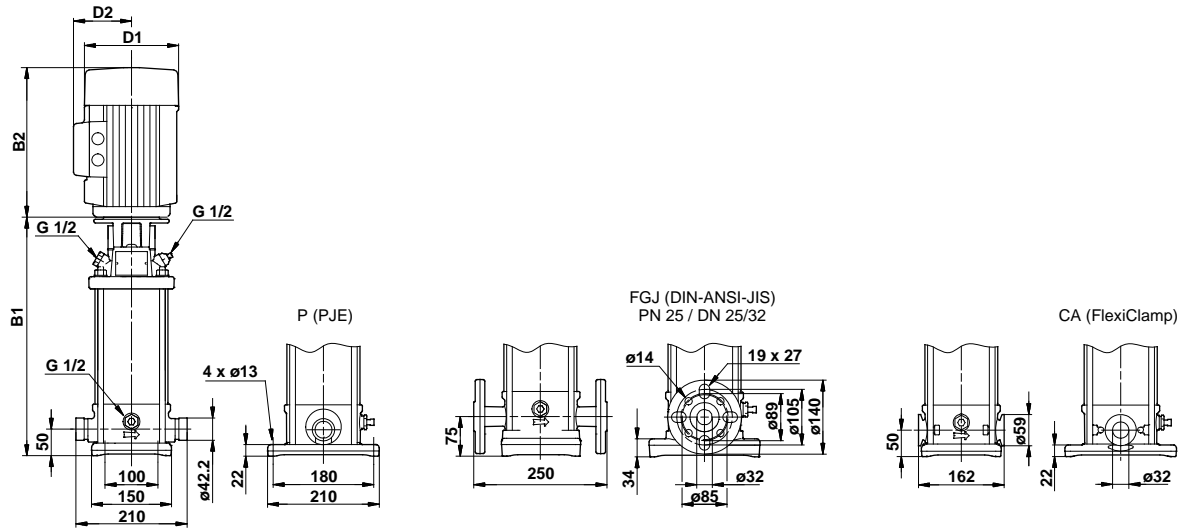

TM03 1722 2805

Dimensions and weights

Pump type	Motor P ₂ [kW]	CRI/CRN							
		Dimension [mm]				Net weight [kg]			
		PJE/CA		DIN flange		D1	D2	PJE/CA	DIN flange
B1	B1+B2	B1	B1+B2						
CRI/CRN 1-2	0.37	257	448	282	473	141	109	16	20
CRI/CRN 1-3	0.37	257	448	282	473	141	109	16	21
CRI/CRN 1-4	0.37	275	466	300	491	141	109	17	21
CRI/CRN 1-5	0.37	293	484	318	509	141	109	17	21
CRI/CRN 1-6	0.37	311	502	336	527	141	109	18	22
CRI/CRN 1-7	0.37	329	520	354	545	141	109	18	22
CRI/CRN 1-8	0.55	347	538	372	563	141	109	19	23
CRI/CRN 1-9	0.55	365	556	390	581	141	109	20	24
CRI/CRN 1-10	0.55	383	574	408	599	141	109	20	24
CRI/CRN 1-11	0.55	401	592	426	617	141	109	20	24
CRI/CRN 1-12	0.75	425	656	450	681	141	109	23	27
CRI/CRN 1-13	0.75	443	674	468	699	141	109	23	28
CRI/CRN 1-15	0.75	479	710	504	735	141	109	24	28
CRI/CRN 1-17	1.10	515	766	540	791	141	109	27	31
CRI/CRN 1-19	1.10	551	802	576	827	141	109	28	32
CRI/CRN 1-21	1.10	587	838	612	863	141	109	29	33
CRI/CRN 1-23	1.10	623	874	648	899	141	109	30	34
CRI/CRN 1-25	1.50	675	956	700	981	178	110	37	41
CRI/CRN 1-27	1.50	711	992	736	1017	178	110	38	42
CRI/CRN 1-30	1.50	765	1046	790	1071	178	110	39	43
CRI/CRN 1-33	2.20	819	1140	844	1165	178	110	41	45
CRI/CRN 1-36	2.20	873	1194	898	1219	178	110	42	46

CR 3

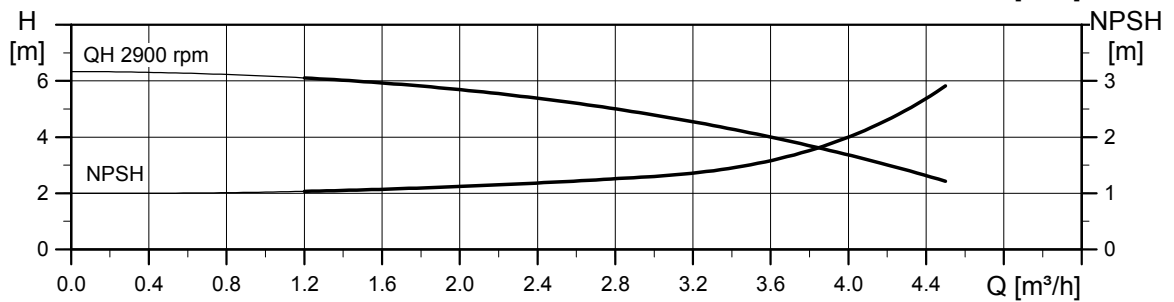
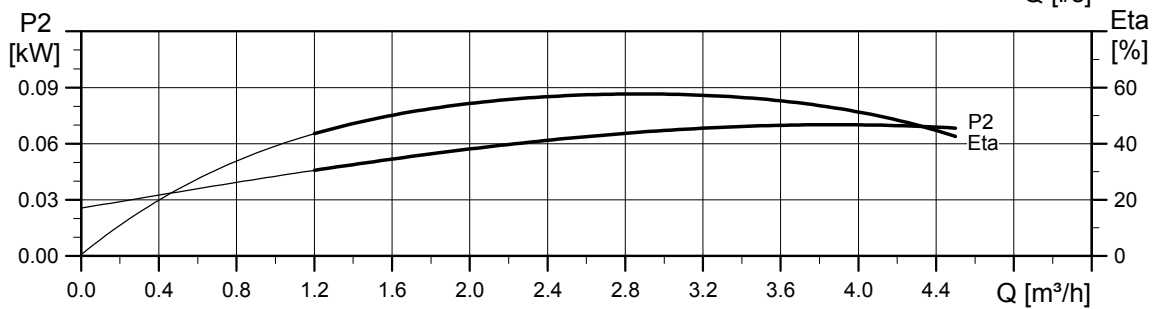
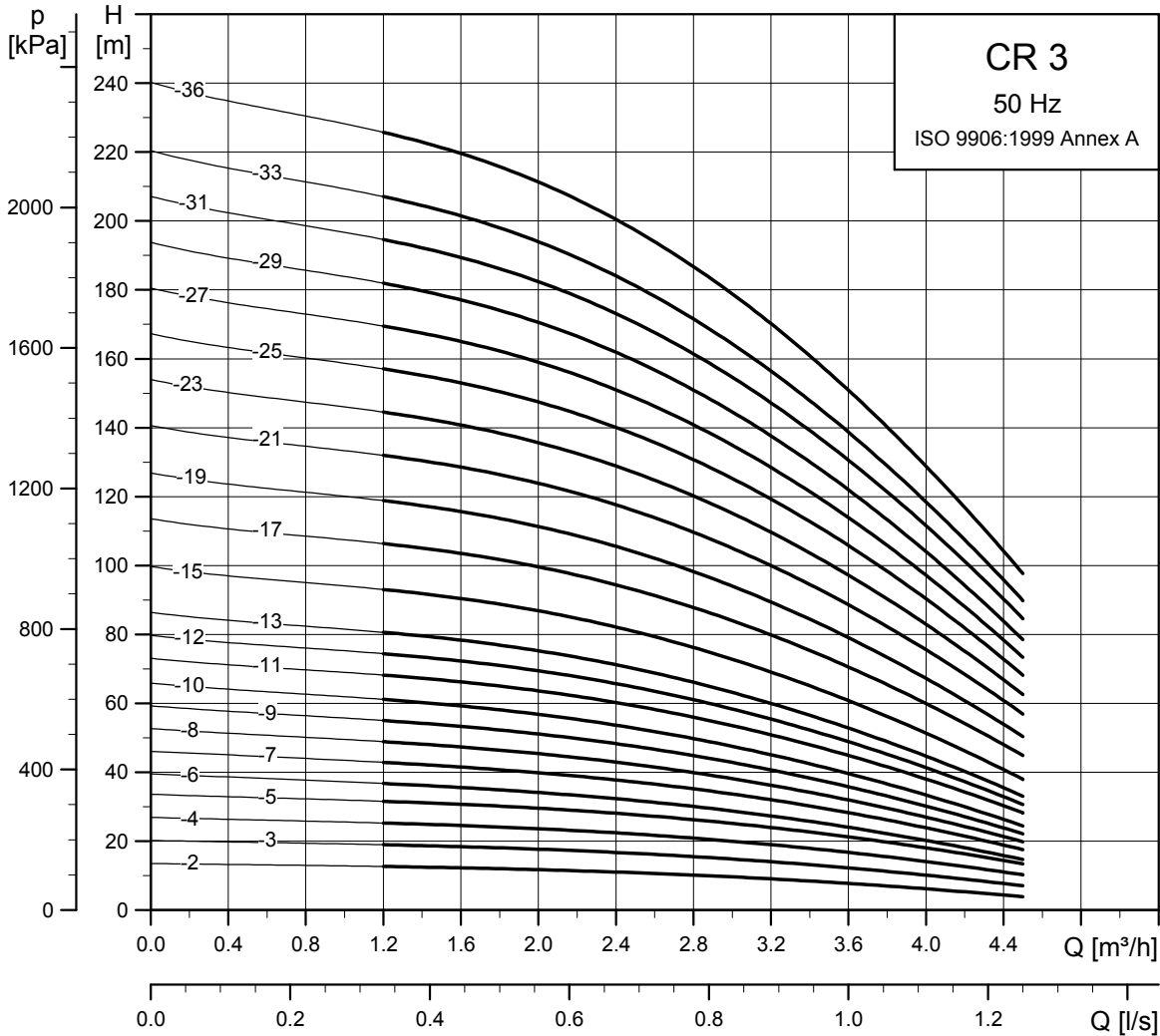

TM02 7292 1013

Dimensional sketch

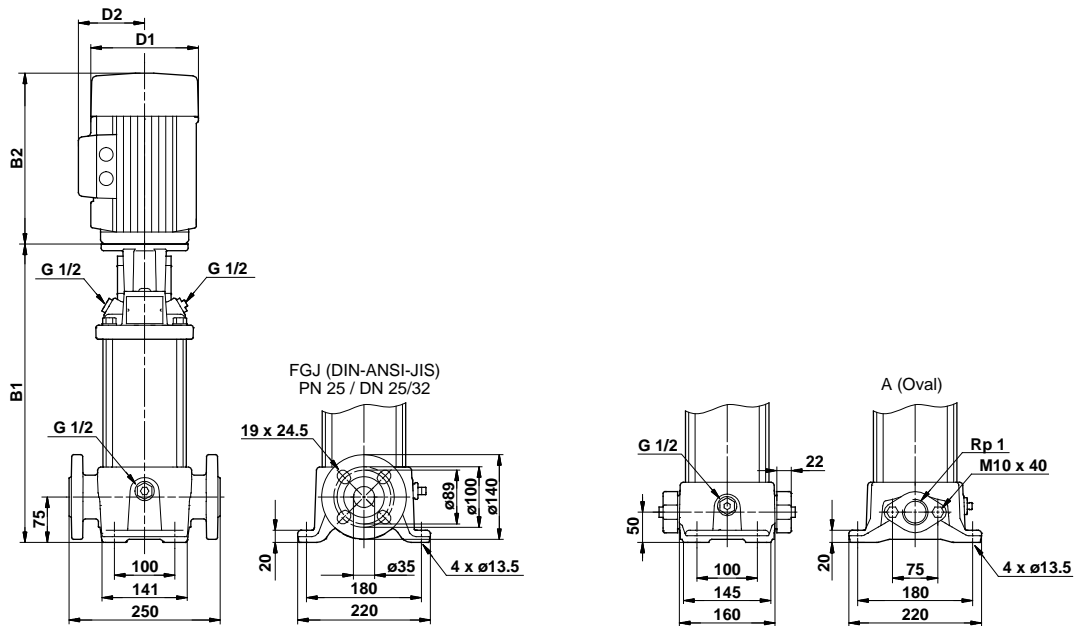

TM03 1721 2805

Dimensions and weights

Pump type	Motor P ₂ [kW]	CR							
		Dimension [mm]						Net weight [kg]	
		Oval flange		DIN flange		D1	D2	Oval flange	DIN flange
B1	B1+B2	B1	B1+B2						
CR 3-2	0.37	254	445	279	470	141	109	18	23
CR 3-3	0.37	254	445	279	470	141	109	18	23
CR 3-4	0.37	272	463	297	488	141	109	19	23
CR 3-5	0.37	290	481	315	506	141	109	19	24
CR 3-6	0.55	308	499	333	524	141	109	20	25
CR 3-7	0.55	326	517	351	542	141	109	21	25
CR 3-8	0.75	350	581	375	606	141	109	23	27
CR 3-9	0.75	368	599	393	624	141	109	23	28
CR 3-10	0.75	386	617	411	642	141	109	24	28
CR 3-11	1.1	404	655	429	680	141	109	26	31
CR 3-12	1.1	422	673	447	698	141	109	27	31
CR 3-13	1.1	440	691	465	716	141	109	27	32
CR 3-15	1.1	476	727	501	752	141	109	28	32
CR 3-17	1.5	528	809	553	834	178	110	36	40
CR 3-19	1.5	564	845	589	870	178	110	37	41
CR 3-21	2.2	600	921	625	946	178	110	38	42
CR 3-23	2.2	636	957	661	982	178	110	39	43
CR 3-25	2.2	-	-	697	1018	178	110	-	44
CR 3-27	2.2	-	-	733	1054	178	110	-	45
CR 3-29	2.2	-	-	769	1090	178	110	-	46
CR 3-31	3	-	-	809	1144	198	120	-	53
CR 3-33	3	-	-	845	1180	198	120	-	53
CR 3-36	3	-	-	899	1234	198	120	-	55

CRI, CRN 3

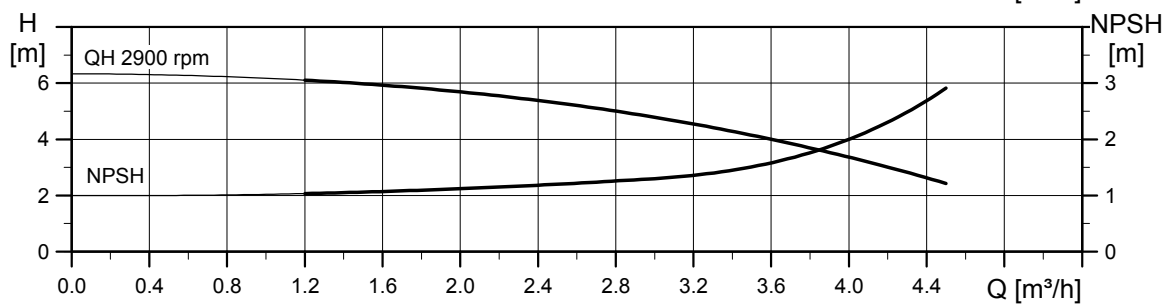
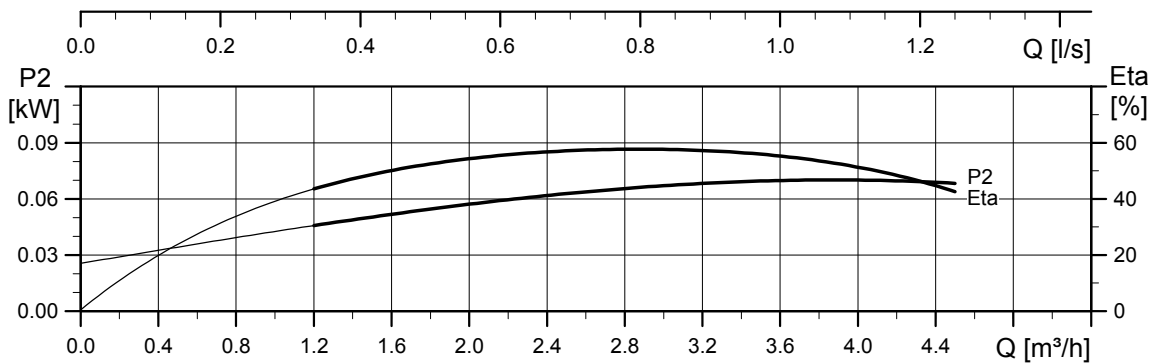
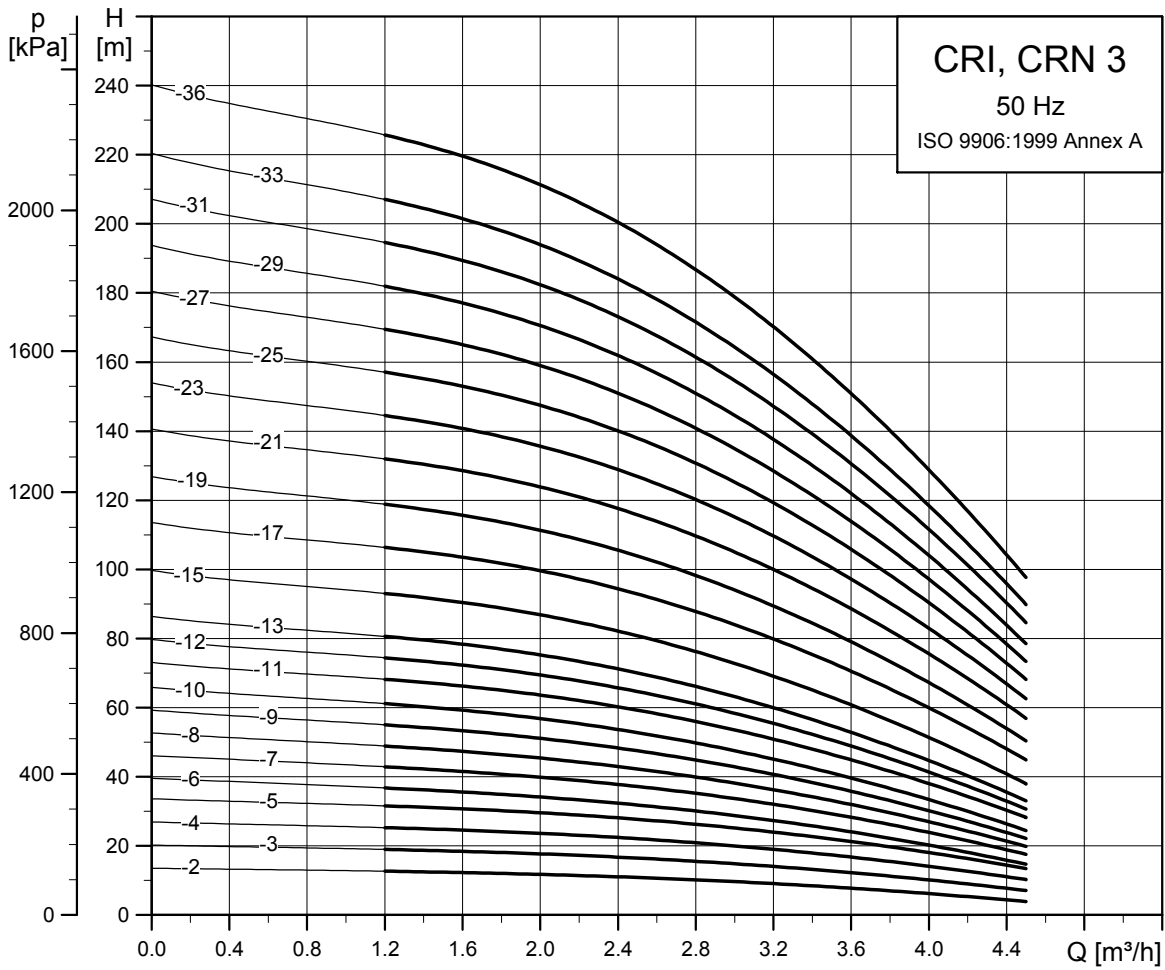

TM02 7293 1013

Dimensional sketch

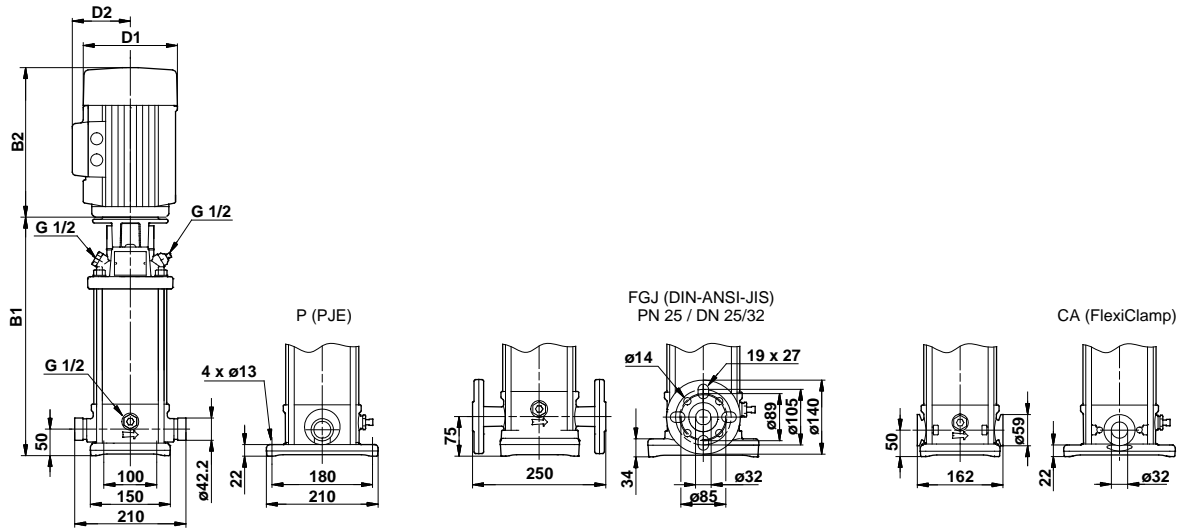

TM03 1722 2805

Dimensions and weights

Pump type	Motor P ₂ [kW]	CRI/CRN							
		Dimension [mm]						Net weight [kg]	
		PJE/CA		DIN flange		D1	D2	PJE/CA	DIN flange
B1	B1+B2	B1	B1+B2						
CRI/CRN 3-2	0.37	257	448	282	473	141	109	16	20
CRI/CRN 3-3	0.37	257	448	282	473	141	109	16	21
CRI/CRN 3-4	0.37	275	466	300	491	141	109	17	21
CRI/CRN 3-5	0.37	293	484	318	509	141	109	17	21
CRI/CRN 3-6	0.55	311	502	336	527	141	109	18	23
CRI/CRN 3-7	0.55	329	520	354	545	141	109	19	23
CRI/CRN 3-8	0.75	353	584	378	609	141	109	21	26
CRI/CRN 3-9	0.75	371	602	396	627	141	109	22	26
CRI/CRN 3-10	0.75	389	620	414	645	141	109	22	26
CRI/CRN 3-11	1.10	407	658	432	683	141	109	25	29
CRI/CRN 3-12	1.10	425	676	450	701	141	109	25	29
CRI/CRN 3-13	1.10	443	694	468	719	141	109	26	30
CRI/CRN 3-15	1.10	479	730	504	755	141	109	26	31
CRI/CRN 3-17	1.50	531	812	556	837	178	110	34	38
CRI/CRN 3-19	1.50	567	848	592	873	178	110	34	39
CRI/CRN 3-21	2.20	603	924	628	949	178	110	36	40
CRI/CRN 3-23	2.20	639	960	664	985	178	110	37	41
CRI/CRN 3-25	2.20	675	996	700	1021	178	110	37	42
CRI/CRN 3-27	2.20	711	1032	736	1057	178	110	38	42
CRI/CRN 3-29	2.20	747	1068	772	1093	178	110	39	43
CRI/CRN 3-31	3.00	788	1123	813	1148	198	120	46	50
CRI/CRN 3-33	3.00	824	1159	849	1184	198	120	47	51
CRI/CRN 3-36	3.00	878	1213	903	1238	198	120	48	52

CR 5

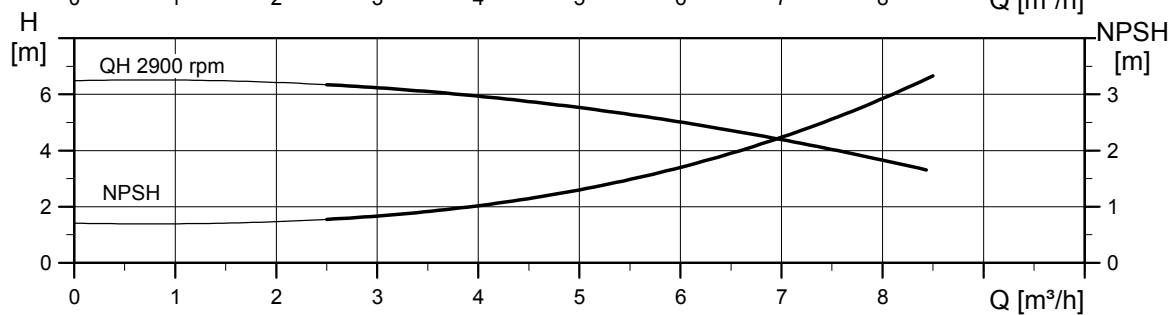
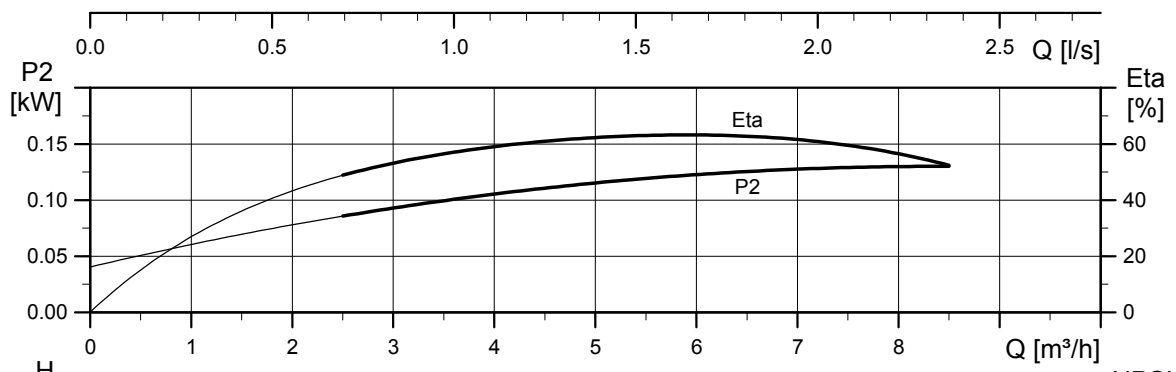
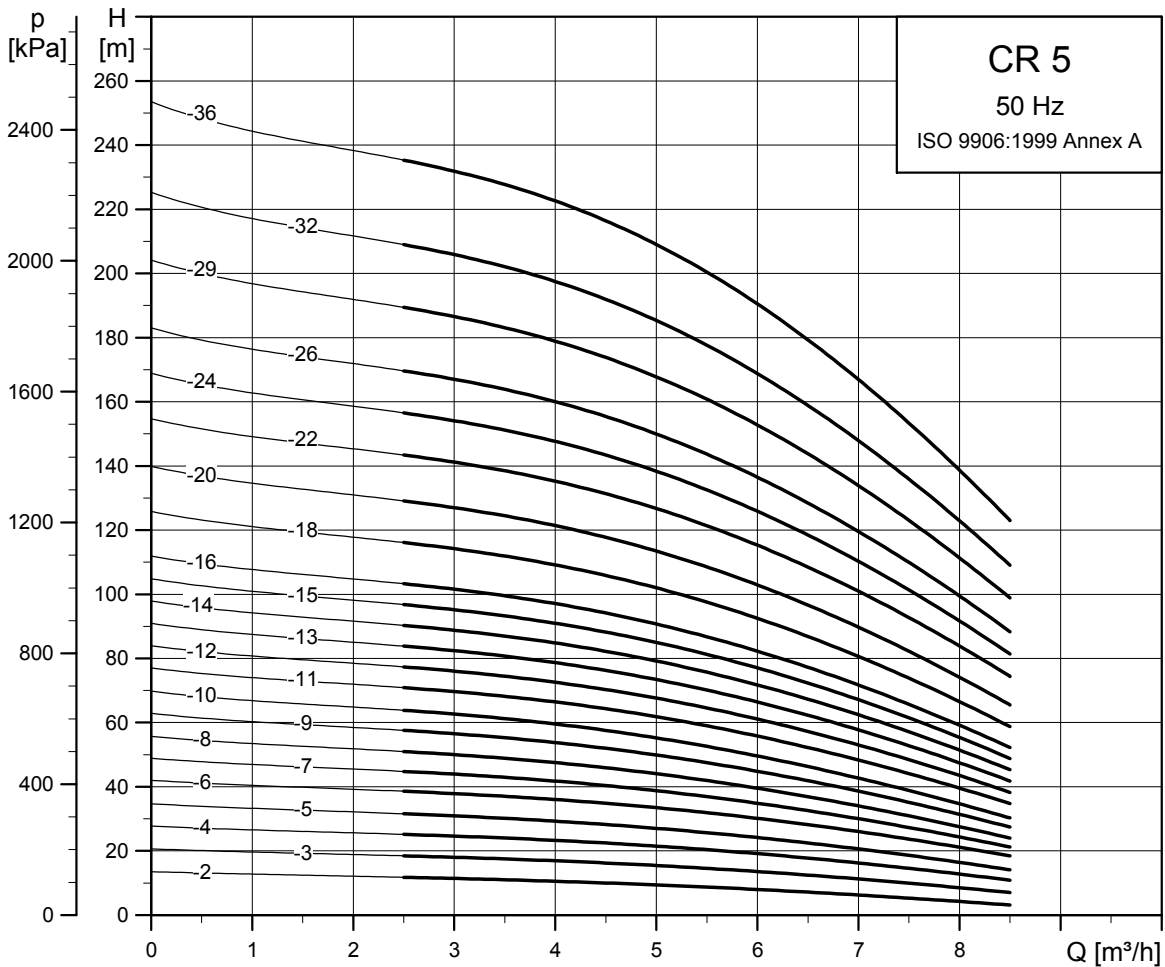

TM02 7294 1013

Dimensional sketch

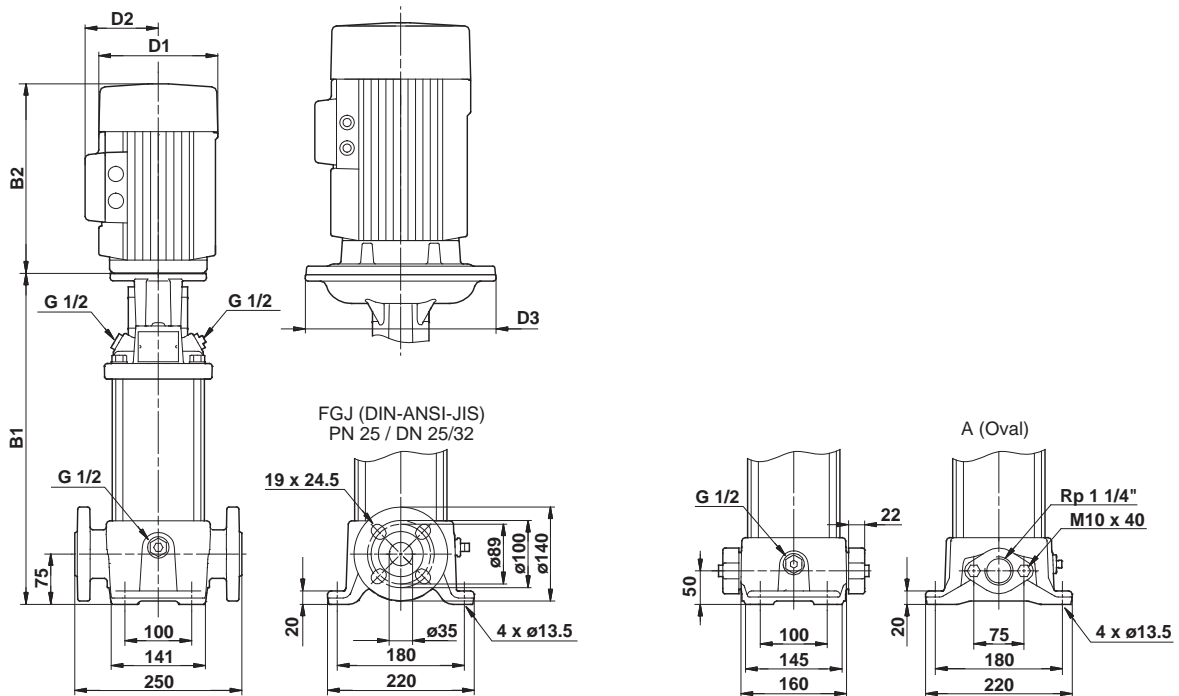

TM03 1723 2805

Dimensions and weights

Pump type	Motor P ₂ [kW]	CR								
		Dimension [mm]						Net weight [kg]		
		Oval flange		DIN flange		D1	D2	D3	Oval flange	DIN flange
		B1	B1+B2	B1	B1+B2					
CR 5-2	0.37	254	445	279	470	141	109	-	18	23
CR 5-3	0.55	281	472	306	497	141	109	-	20	24
CR 5-4	0.55	308	499	333	524	141	109	-	20	25
CR 5-5	0.75	341	572	366	597	141	109	-	22	27
CR 5-6	1.10	368	619	393	644	141	109	-	25	30
CR 5-7	1.10	395	646	420	671	141	109	-	26	30
CR 5-8	1.10	422	673	447	698	141	109	-	26	31
CR 5-9	1.50	465	746	490	771	178	110	-	34	38
CR 5-10	1.50	492	773	517	798	178	110	-	34	39
CR 5-11	2.20	519	840	544	865	178	110	-	36	40
CR 5-12	2.20	546	867	571	892	178	110	-	36	41
CR 5-13	2.20	573	894	598	919	178	110	-	37	41
CR 5-14	2.20	600	921	625	946	178	110	-	37	42
CR 5-15	2.20	627	948	652	973	178	110	-	38	43
CR 5-16	2.20	654	975	679	1000	178	110	-	38	43
CR 5-18	3.00	712	1047	737	1072	198	120	-	46	50
CR 5-20	3.00	766	1101	791	1126	198	120	-	47	52
CR 5-22	4.00	820	1192	845	1217	220	134	-	57	62
CR 5-24	4.00	-	-	899	1271	220	134	-	-	63
CR 5-26	4.00	-	-	953	1325	220	134	-	-	64
CR 5-29	4.00	-	-	1034	1406	220	134	-	-	66
CR 5-32	5.50	-	-	1145	1536	220	134	300	-	82
CR 5-36	5.50	-	-	1253	1644	220	134	300	-	84

CRI, CRN 5

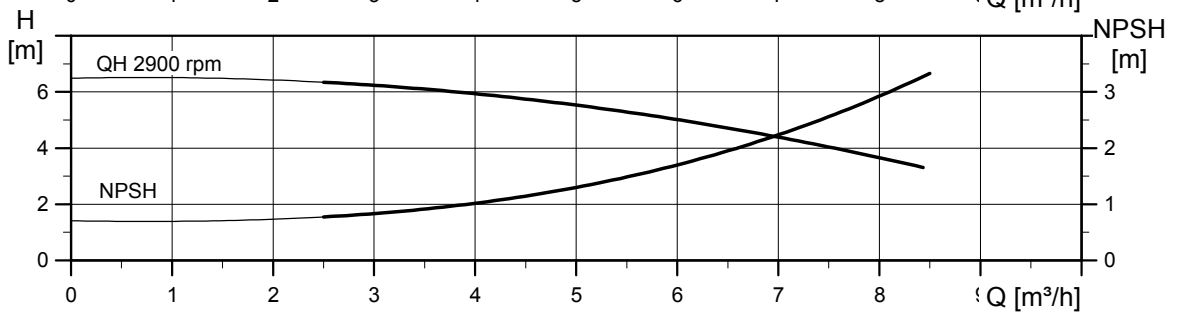
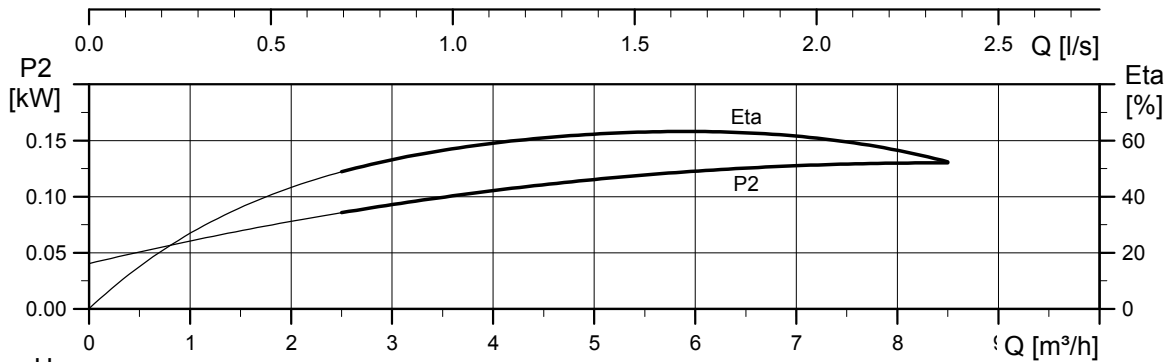
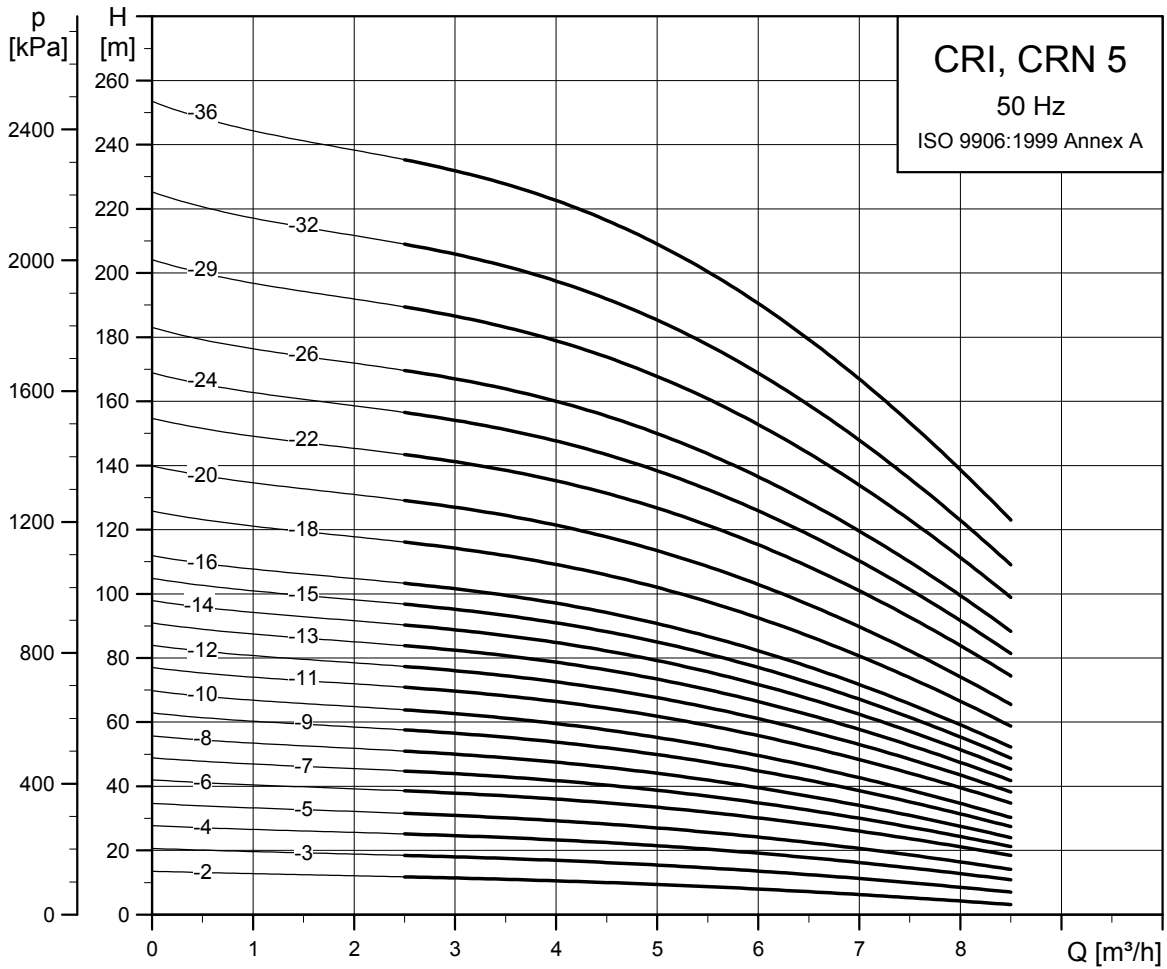

TM02 7295 1013

Dimensional sketch

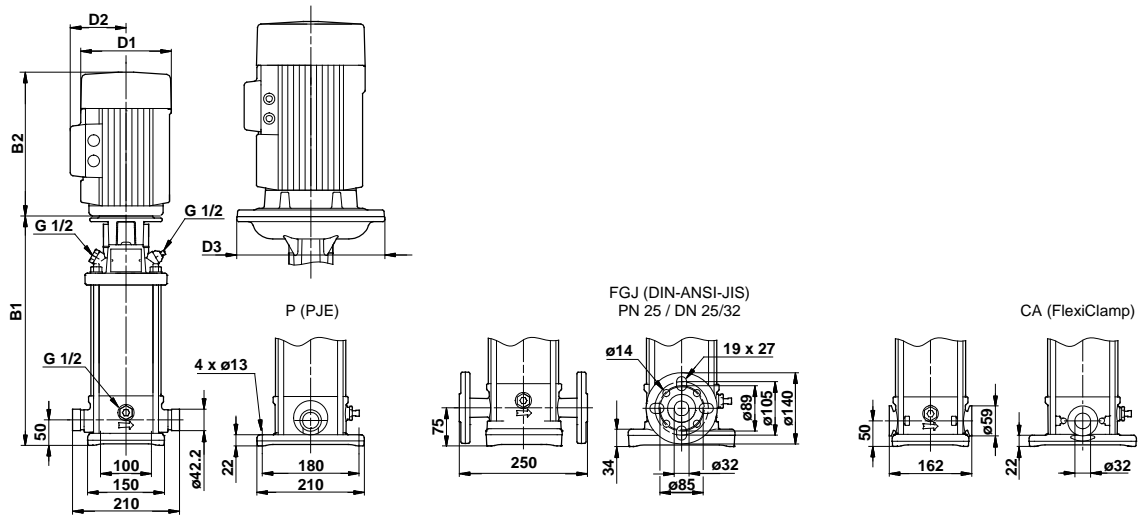

TM03 1724 2805

Dimensions and weights

Pump type	Motor P ₂ [kW]	CRI/CRN								
		Dimension [mm]							Net weight [kg]	
		PJE/CA		DIN flange		D1	D2	D3	PJE/CA	DIN flange
		B1	B1+B2	B1	B1+B2					
CRI/CRN 5-2	0.37	257	448	282	473	141	109	-	16	21
CRI/CRN 5-3	0.55	284	475	309	500	141	109	-	18	22
CRI/CRN 5-4	0.55	311	502	336	527	141	109	-	18	22
CRI/CRN 5-5	0.75	344	575	369	600	141	109	-	21	25
CRI/CRN 5-6	1.10	371	622	396	647	141	109	-	24	28
CRI/CRN 5-7	1.10	398	649	423	674	141	109	-	24	29
CRI/CRN 5-8	1.10	425	676	450	701	141	109	-	25	29
CRI/CRN 5-9	1.50	468	749	493	774	178	110	-	32	36
CRI/CRN 5-10	1.50	495	776	520	801	178	110	-	32	37
CRI/CRN 5-11	2.20	522	843	547	868	178	110	-	34	38
CRI/CRN 5-12	2.20	549	870	574	895	178	110	-	34	38
CRI/CRN 5-13	2.20	576	897	601	922	178	110	-	35	39
CRI/CRN 5-14	2.20	603	924	628	949	178	110	-	35	40
CRI/CRN 5-15	2.20	630	951	655	976	178	110	-	36	40
CRI/CRN 5-16	2.20	657	978	682	1003	178	110	-	36	41
CRI/CRN 5-18	3.00	716	1051	741	1076	198	120	-	44	48
CRI/CRN 5-20	3.00	770	1105	795	1130	198	120	-	45	49
CRI/CRN 5-22	4.00	824	1196	849	1221	220	134	-	55	59
CRI/CRN 5-24	4.00	878	1250	903	1275	220	134	-	56	61
CRI/CRN 5-26	4.00	932	1304	957	1329	220	134	-	58	62
CRI/CRN 5-29	4.00	1013	1385	1038	1410	220	134	-	59	64
CRI/CRN 5-32	5.50	1123	1514	1148	1539	220	134	300	75	79
CRI/CRN 5-36	5.50	1231	1622	1256	1647	220	134	300	77	81

CR 10

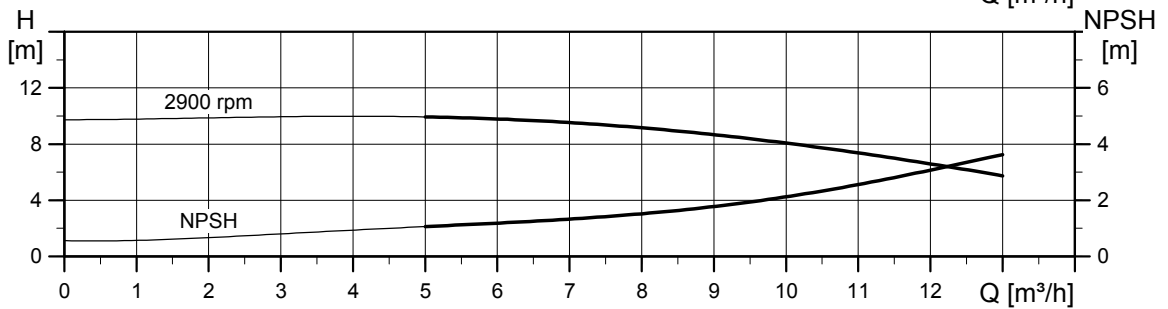
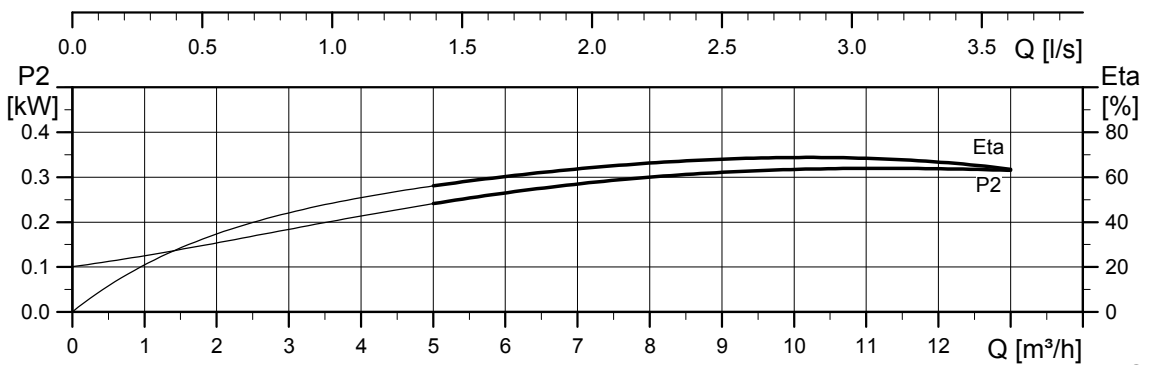
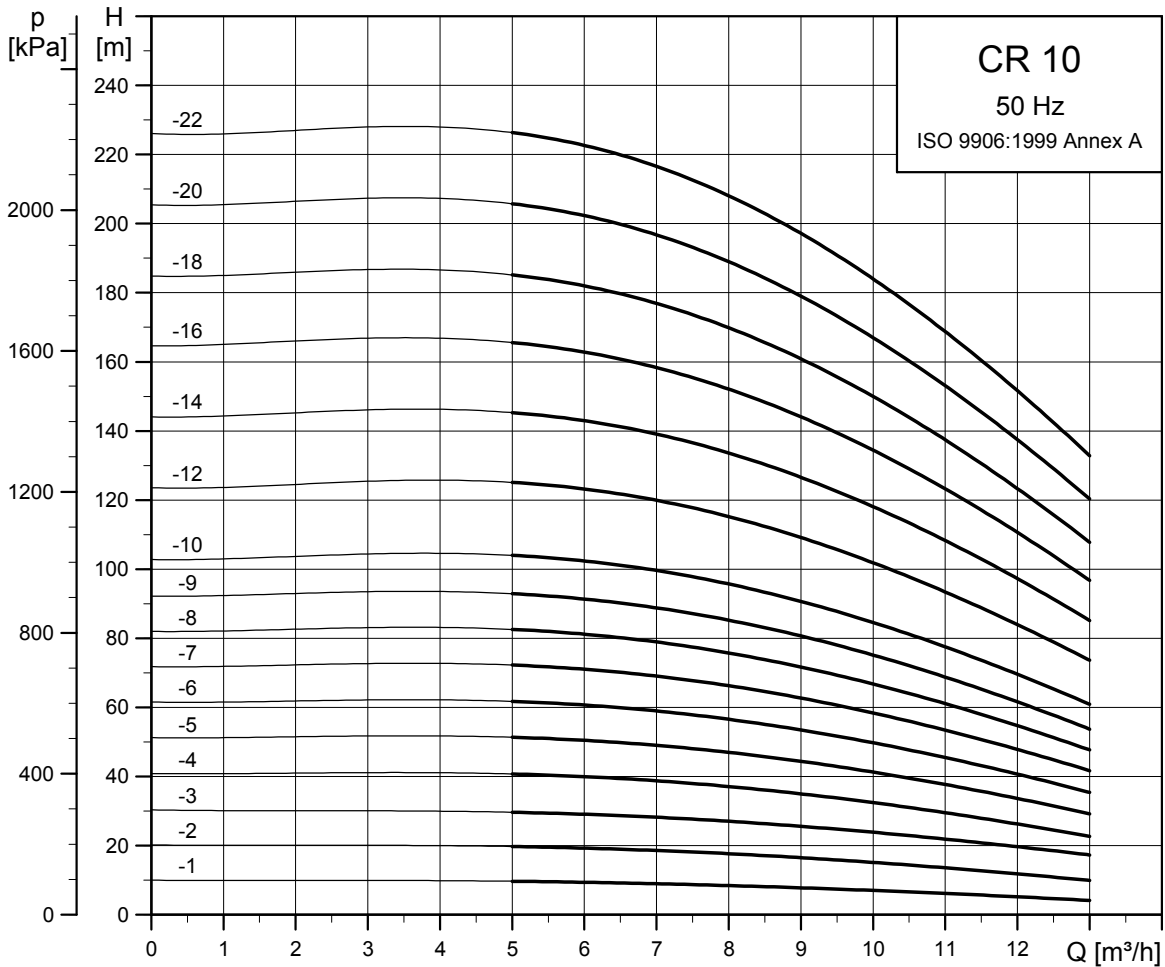

TM02 7296 1013

Dimensional sketch

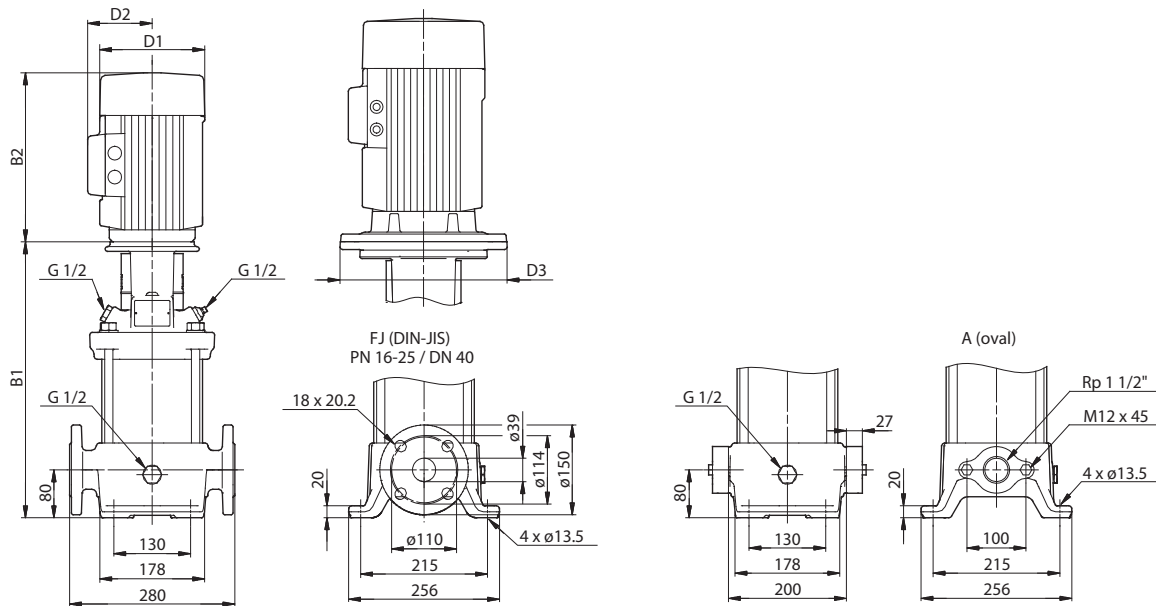

TM03 1725 2805

Dimensions and weights

Pump type	Motor P ₂ [kW]	CR									
		Dimension [mm]								Net weight [kg]	
		Oval flange		DIN flange		D1	D2	D3	Oval flange	DIN flange	
B1	B1+B2	B1	B1+B2								
CR 10-1	0.37	343	534	343	534	141	109	-	31	34	
CR 10-2	0.75	347	578	347	578	141	109	-	34	36	
CR 10-3	1.10	377	628	377	628	141	109	-	37	39	
CR 10-4	1.50	423	704	423	704	178	110	-	45	47	
CR 10-5	2.20	453	774	453	774	178	110	-	46	49	
CR 10-6	2.20	483	804	483	804	178	110	-	47	50	
CR 10-7	3.00	518	853	518	853	198	120	-	54	57	
CR 10-8	3.00	548	883	548	883	198	120	-	55	58	
CR 10-9	3.00	578	913	578	913	198	120	-	56	59	
CR 10-10	4.00	608	980	608	980	220	134	-	66	69	
CR 10-12	4.00	668	1040	668	1040	220	134	-	69	71	
CR 10-14	5.50	760	1151	760	1151	220	134	300	91	94	
CR 10-16	5.50	820	1211	820	1211	220	134	300	93	96	
CR 10-18	7.50	-	-	880	1259	260	159	300	-	109	
CR 10-20	7.50	-	-	940	1319	260	159	300	-	112	
CR 10-22	7.50	-	-	1000	1379	260	159	300	-	114	

CRI, CRN 10

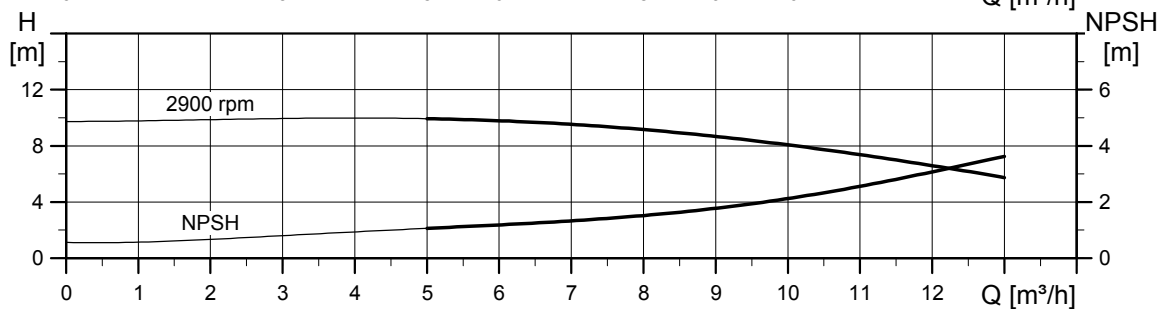
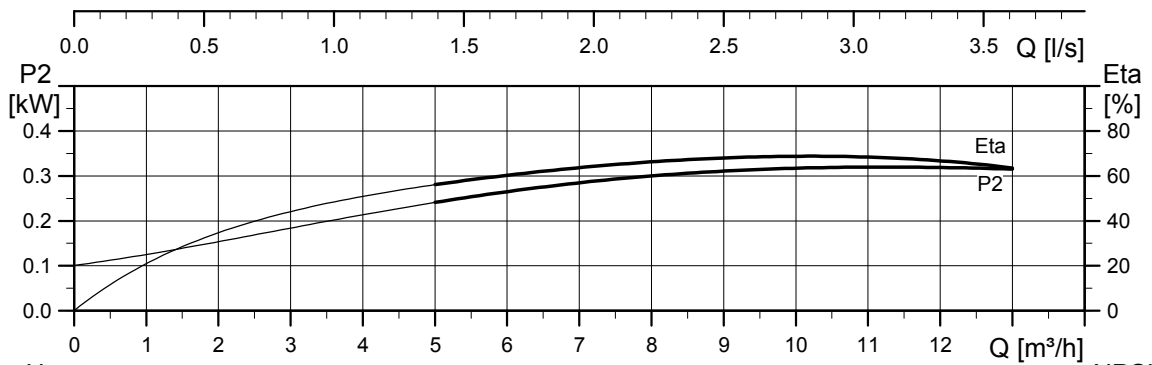
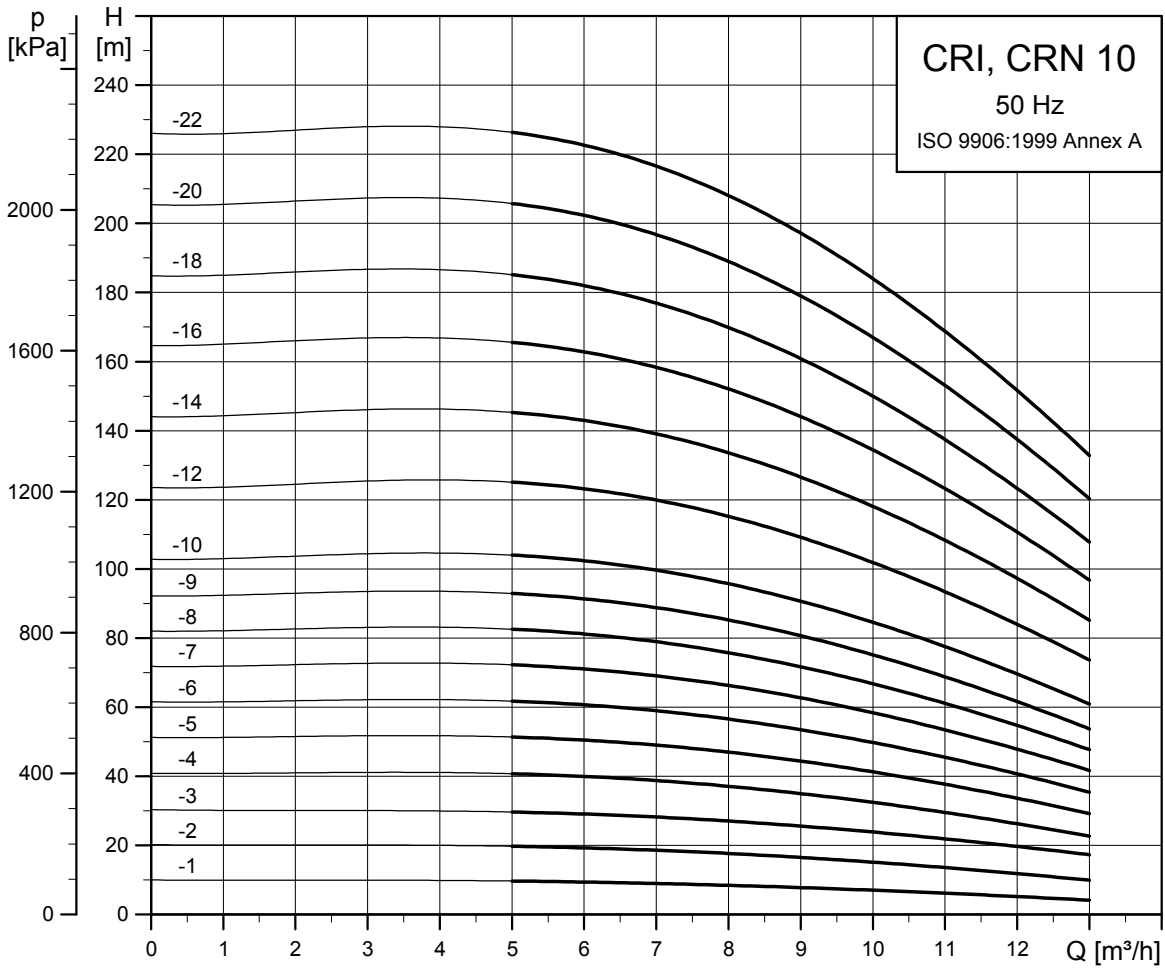

TM02 7297 1013

Dimensional sketch

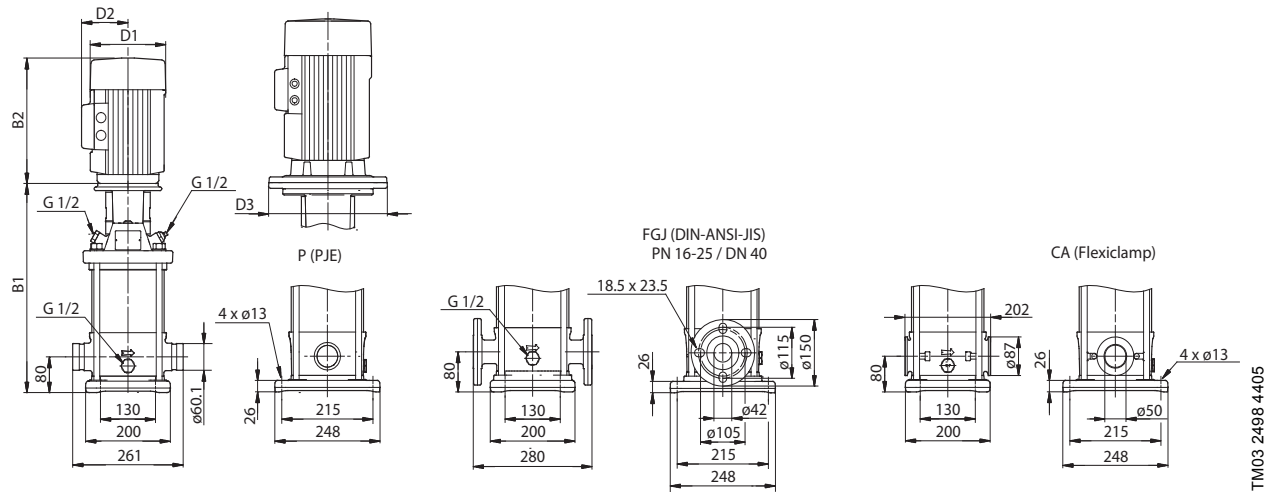

Dimensions and weights

Pump type	Motor P ₂ [kW]	CRI/CRN									
		Dimension [mm]								Net weight [kg]	
		PJE/CA		DIN flange		D1	D2	D3	PJE/CA	DIN flange	
		B1	B1+B2	B1	B1+B2						
CRI/CRN 10-1	0.37	353	544	353	544	141	109	-	28	32	
CRI/CRN 10-2	0.75	357	588	357	588	141	109	-	31	34	
CRI/CRN 10-3	1.10	387	638	387	638	141	109	-	34	38	
CRI/CRN 10-4	1.50	433	714	433	714	178	110	-	42	46	
CRI/CRN 10-5	2.20	463	784	463	784	178	110	-	44	48	
CRI/CRN 10-6	2.20	493	814	493	814	178	110	-	45	49	
CRI/CRN 10-7	3.00	528	863	528	863	198	120	-	52	56	
CRI/CRN 10-8	3.00	558	893	558	893	198	120	-	54	57	
CRI/CRN 10-9	3.00	588	923	588	923	198	120	-	55	58	
CRI/CRN 10-10	4.00	618	990	618	990	220	134	-	65	68	
CRI/CRN 10-12	4.00	678	1050	678	1050	220	134	-	67	70	
CRI/CRN 10-14	5.50	770	1161	770	1161	220	134	300	89	93	
CRI/CRN 10-16	5.50	830	1221	830	1221	220	134	300	91	95	
CRI/CRN 10-18	7.50	890	1269	890	1269	260	159	300	104	108	
CRI/CRN 10-20	7.50	950	1329	950	1329	260	159	300	106	110	
CRI/CRN 10-22	7.50	1010	1389	1010	1389	260	159	300	108	112	

CR 15

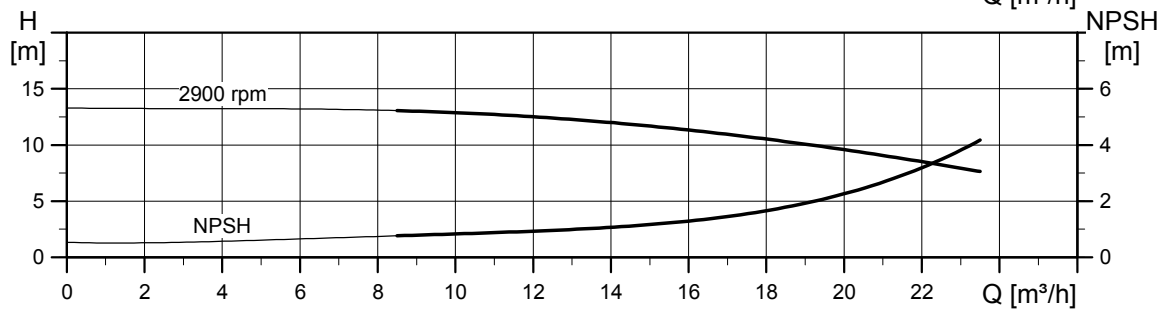
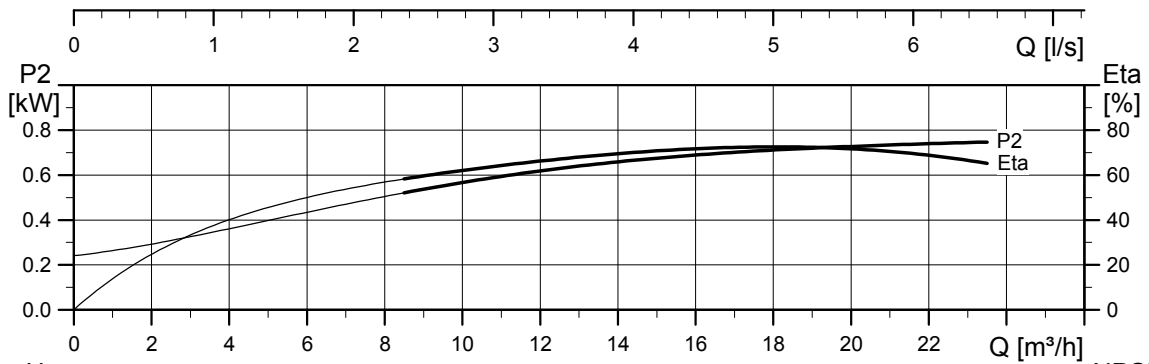
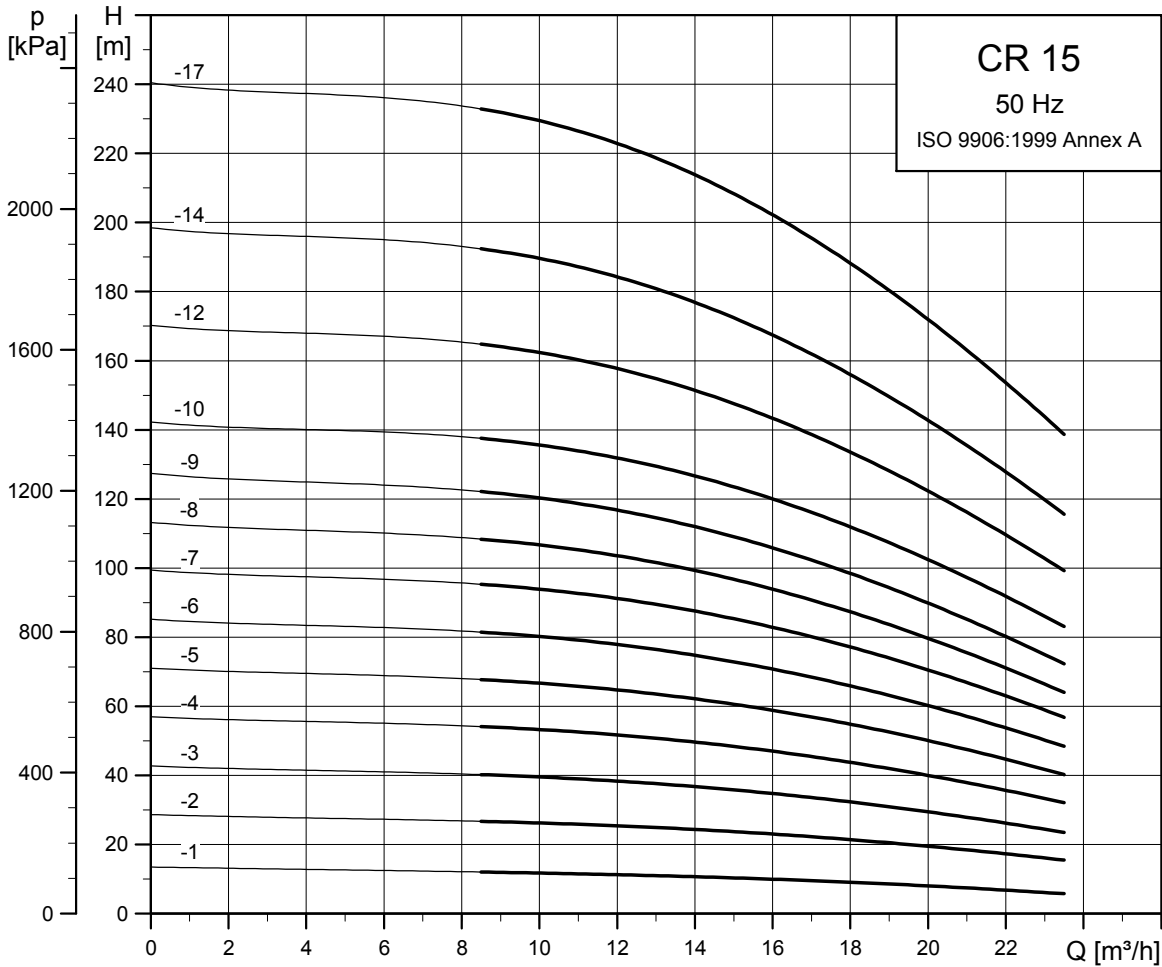

TM02 7298 1013

Dimensional sketch

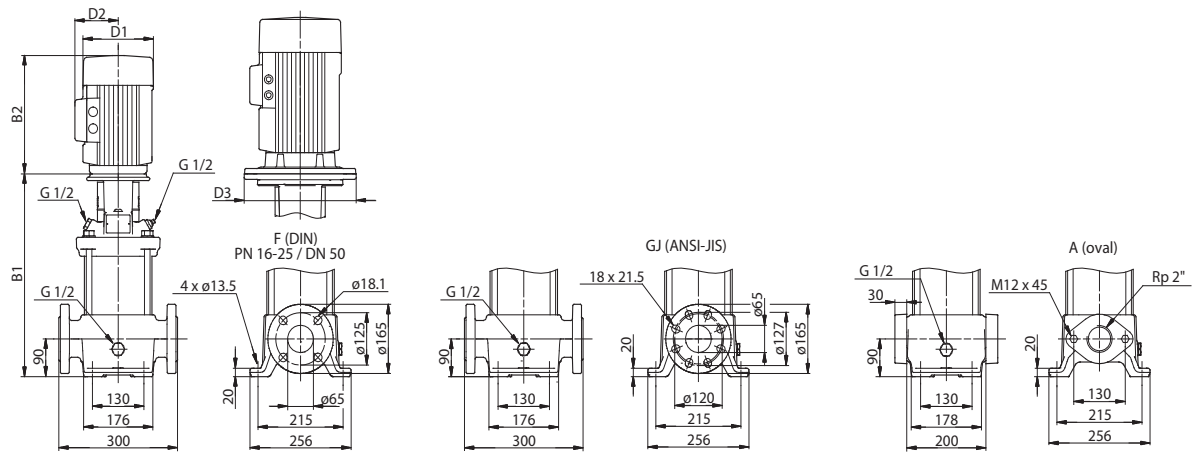

TM03 1727 2805

Dimensions and weights

Pump type	Motor P ₂ [kW]	CR									
		Dimension [mm]								Net weight [kg]	
		Oval flange		DIN flange		D1	D2	D3	Oval flange	DIN flange	
		B1	B1+B2	B1	B1+B2						
CR 15-1	1.10	400	651	400	651	141	109	-	41	42	
CR 15-2	2.20	415	736	415	736	178	110	-	49	50	
CR 15-3	3.00	465	800	465	800	198	120	-	56	57	
CR 15-4	4.00	510	882	510	882	220	134	-	67	68	
CR 15-5	4.00	555	927	555	927	220	134	-	68	69	
CR 15-6	5.50	632	1023	632	1023	220	134	300	90	91	
CR 15-7	5.50	677	1068	677	1068	220	134	300	92	93	
CR 15-8	7.50	-	-	722	1101	260	159	300	-	105	
CR 15-9	7.50	-	-	767	1146	260	159	300	-	107	
CR 15-10	11.00	-	-	889	1360	314	204	350	-	149	
CR 15-12	11.00	-	-	979	1450	314	204	350	-	153	
CR 15-14	11.00	-	-	1069	1540	314	204	350	-	157	
CR 15-17	15.00	-	-	1204	1675	314	204	350	-	175	

CRI, CRN 15

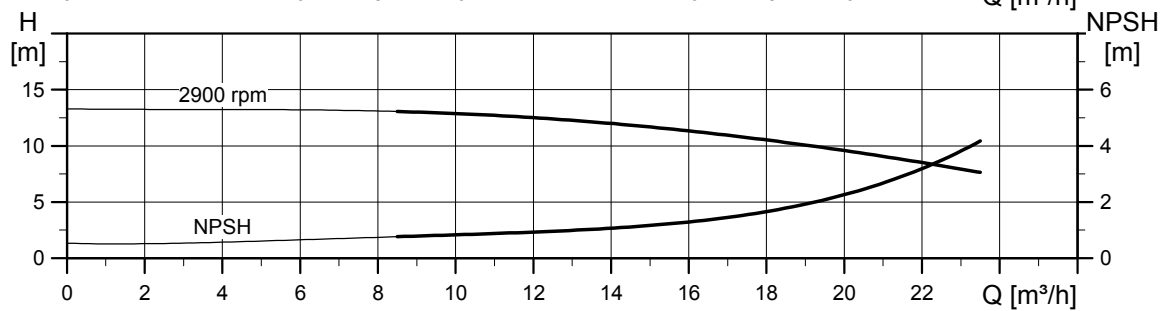
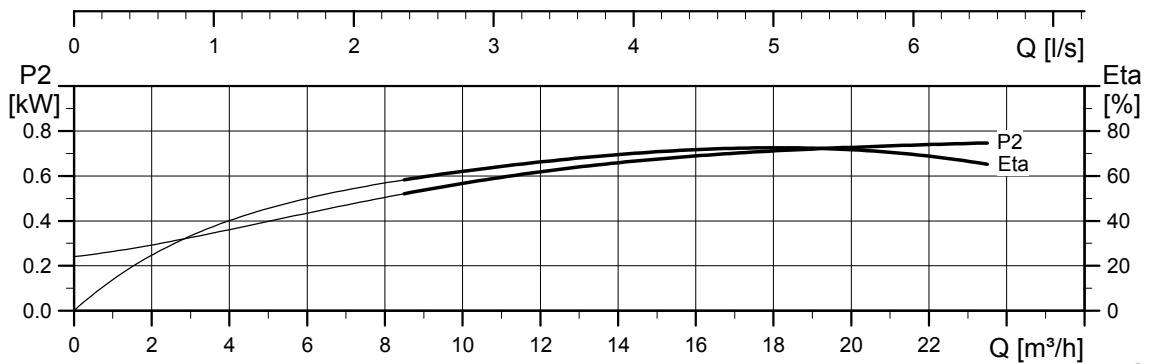
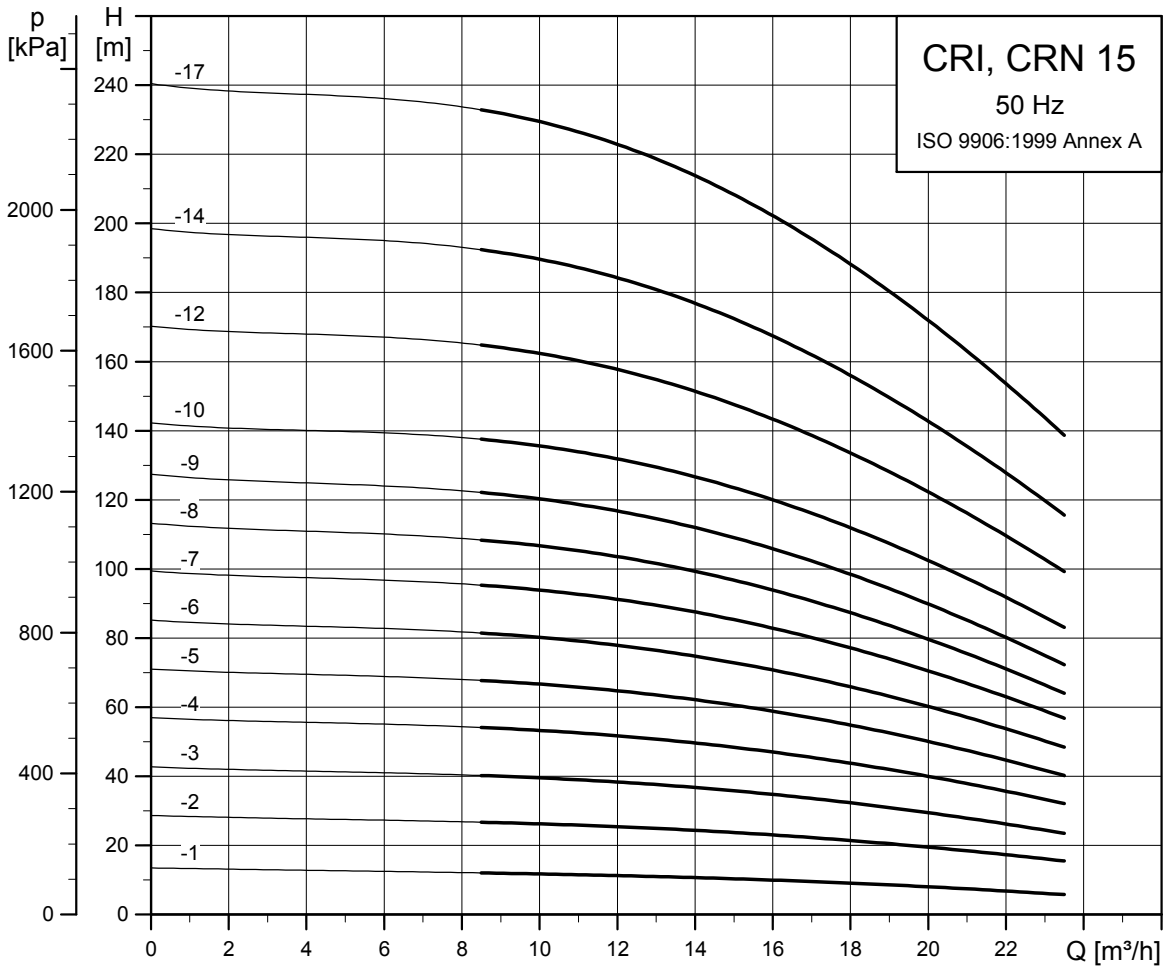

TM02 7299 1013

Dimensional sketch

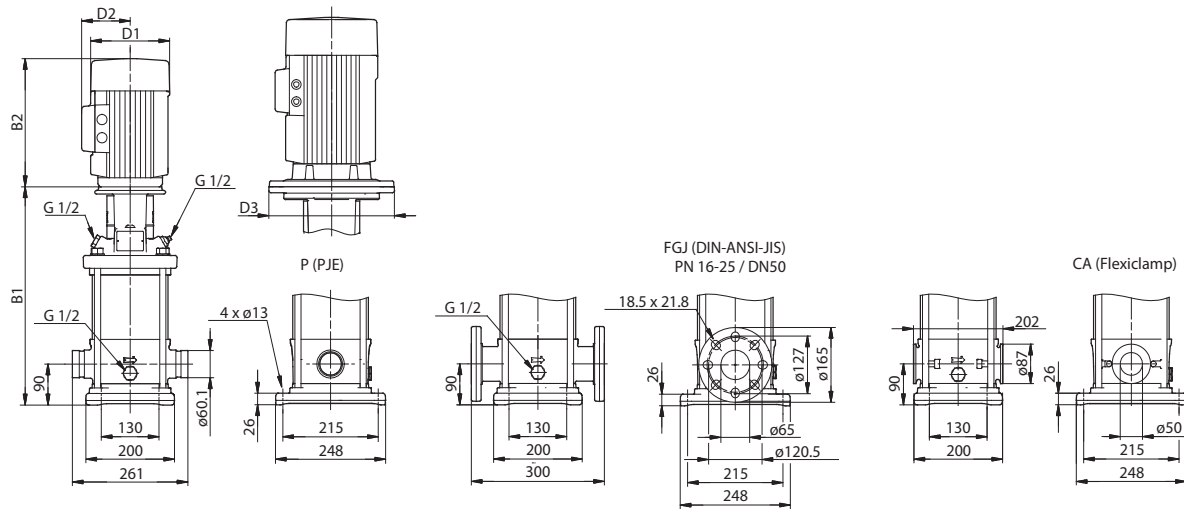

TM03 1728 2805

Dimensions and weights

Pump type	Motor P ₂ [kW]	CRI/CRN								
		Dimension [mm]							Net weight [kg]	
		PJE/CA		DIN flange		D1	D2	D3	PJE/CA	DIN flange
		B1	B1+B2	B1	B1+B2					
CRI/CRN 15-1	1.10	397	648	397	648	141	109	-	34	39
CRI/CRN 15-2	2.20	413	734	413	734	178	110	-	42	47
CRI/CRN 15-3	3.00	463	798	463	798	198	120	-	50	55
CRI/CRN 15-4	4.00	508	880	508	880	220	134	-	61	65
CRI/CRN 15-5	4.00	553	925	553	925	220	134	-	62	67
CRI/CRN 15-6	5.50	630	1021	630	1021	220	134	300	84	89
CRI/CRN 15-7	5.50	675	1066	675	1066	220	134	300	86	90
CRI/CRN 15-8	7.50	720	1099	720	1099	260	159	300	98	103
CRI/CRN 15-9	7.50	765	1144	765	1144	260	159	300	100	104
CRI/CRN 15-10	11.00	887	1358	887	1358	314	204	350	142	147
CRI/CRN 15-12	11.00	977	1448	977	1448	314	204	350	145	150
CRI/CRN 15-14	11.00	1067	1538	1067	1538	314	204	350	149	153
CRI/CRN 15-17	15.00	1202	1673	1202	1673	314	204	350	167	171

CR 20

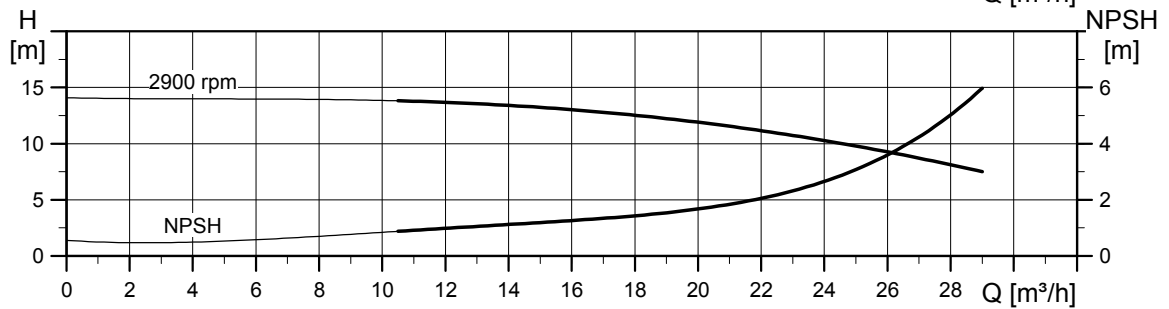
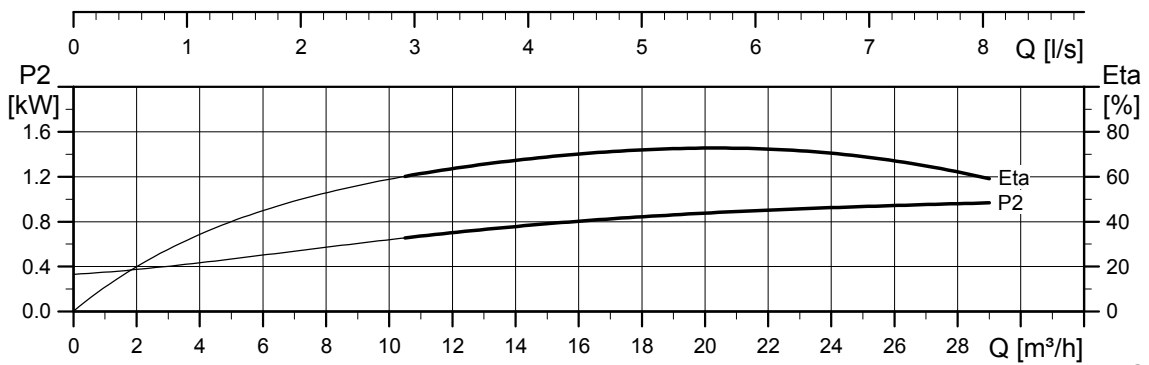
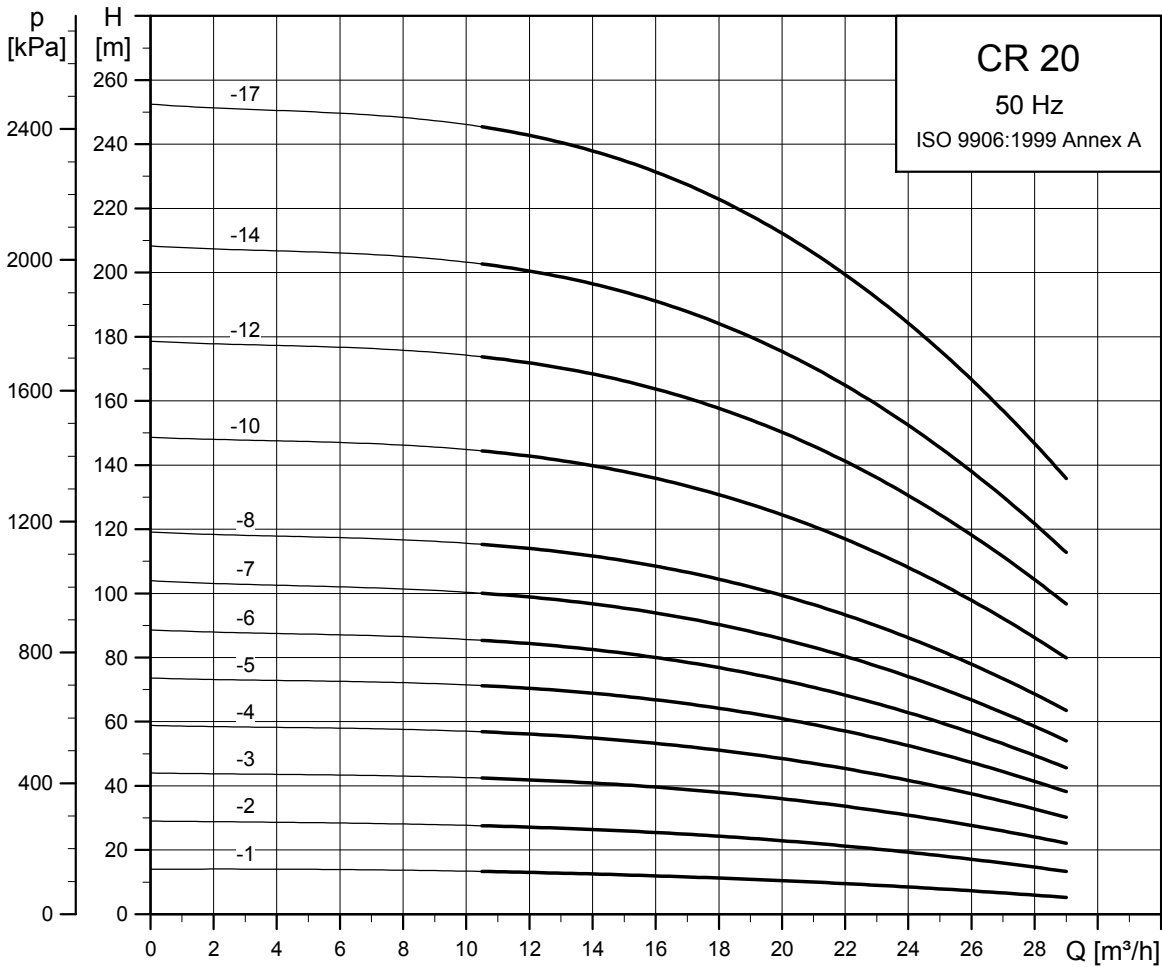

TM02 7300 1013

Dimensional sketch

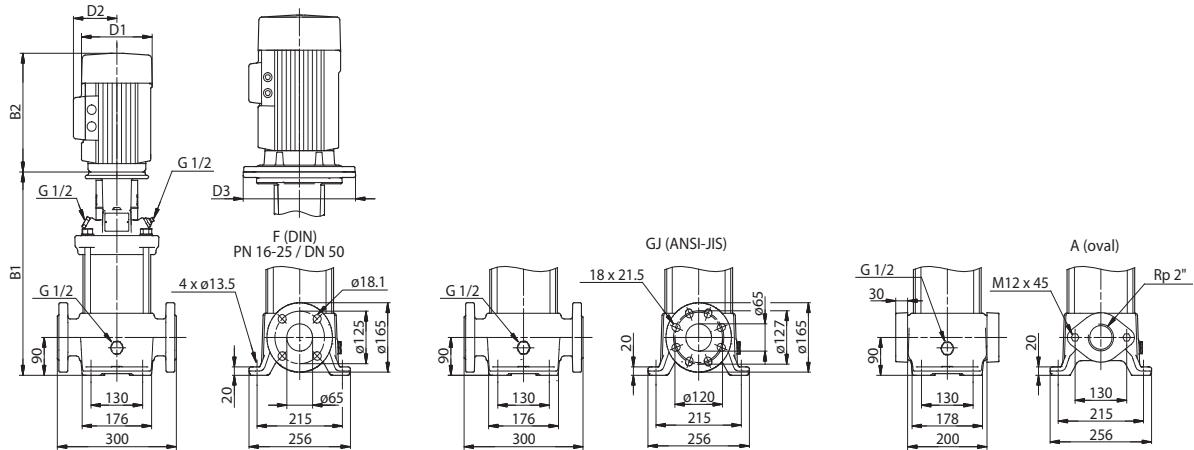

TM03 1727 2805

Dimensions and weights

Pump type	Motor P ₂ [kW]	CR									
		Dimension [mm]								Net weight [kg]	
		Oval flange		DIN flange		D1	D2	D3	Oval flange	DIN flange	
		B1	B1+B2	B1	B1+B2						
CR 20-1	1.10	400	651	400	651	141	109	-	41	42	
CR 20-2	2.20	415	736	415	736	178	110	-	49	50	
CR 20-3	4.00	465	837	465	837	220	134	-	65	66	
CR 20-4	5.50	542	933	542	933	220	134	300	87	88	
CR 20-5	5.50	587	978	587	978	220	134	300	89	90	
CR 20-6	7.50	632	1011	632	1011	260	159	300	101	102	
CR 20-7	7.50	677	1056	677	1056	260	159	300	103	103	
CR 20-8	11.00	-	-	799	1270	314	204	350	-	146	
CR 20-10	11.00	-	-	889	1360	314	204	350	-	149	
CR 20-12	15.00	-	-	979	1450	314	204	350	-	166	
CR 20-14	15.00	-	-	1069	1540	314	204	350	-	170	
CR 20-17	18.50	-	-	1204	1719	314	204	350	-	188	

CRI, CRN 20

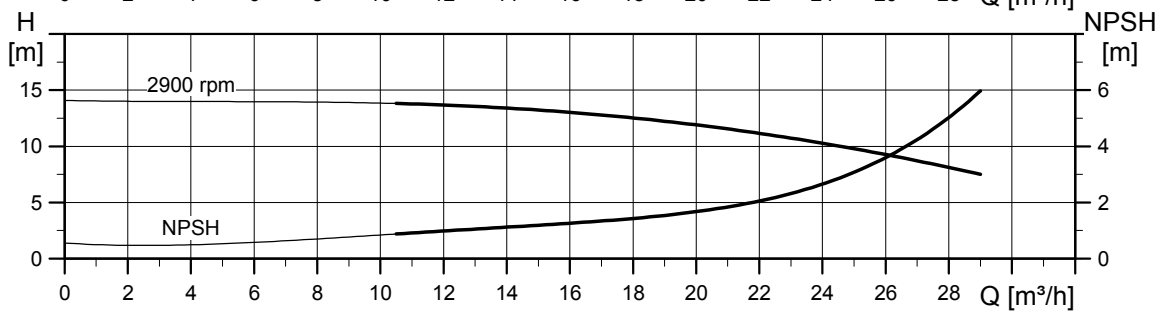
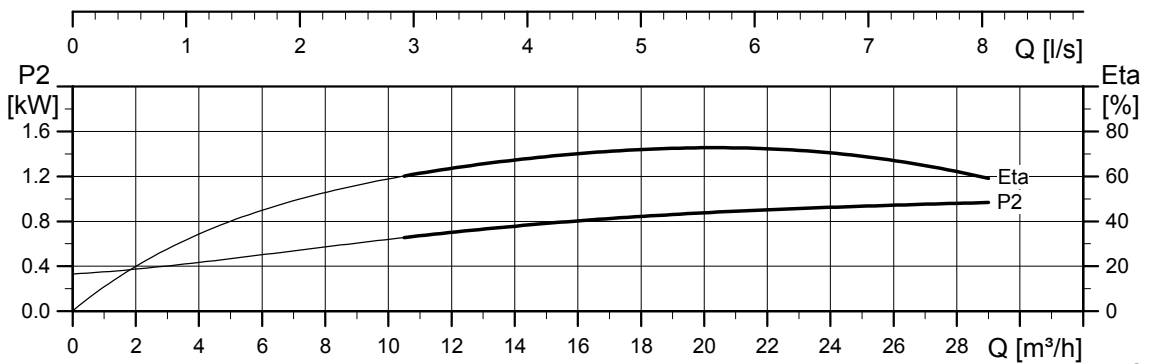
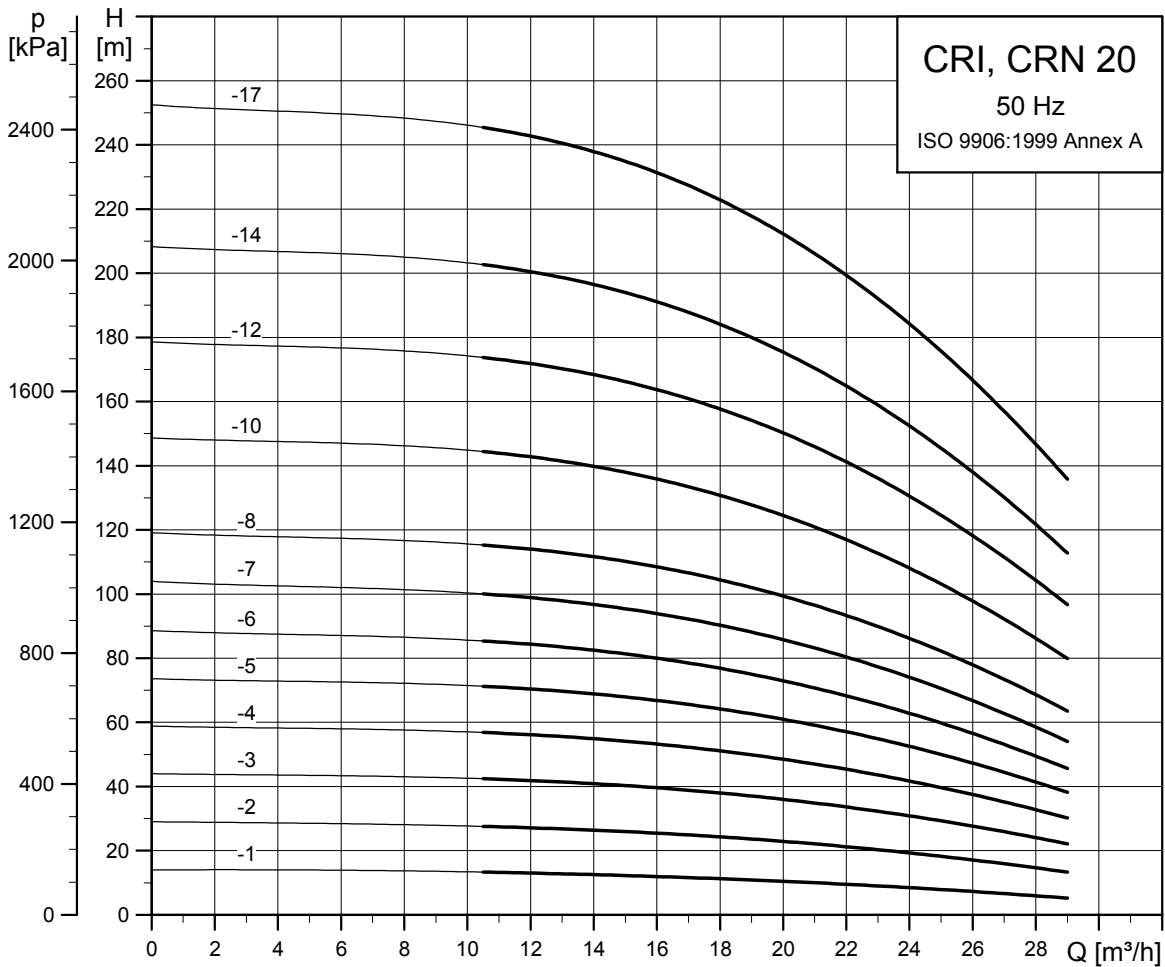

TM02 7301 1013

Dimensional sketch

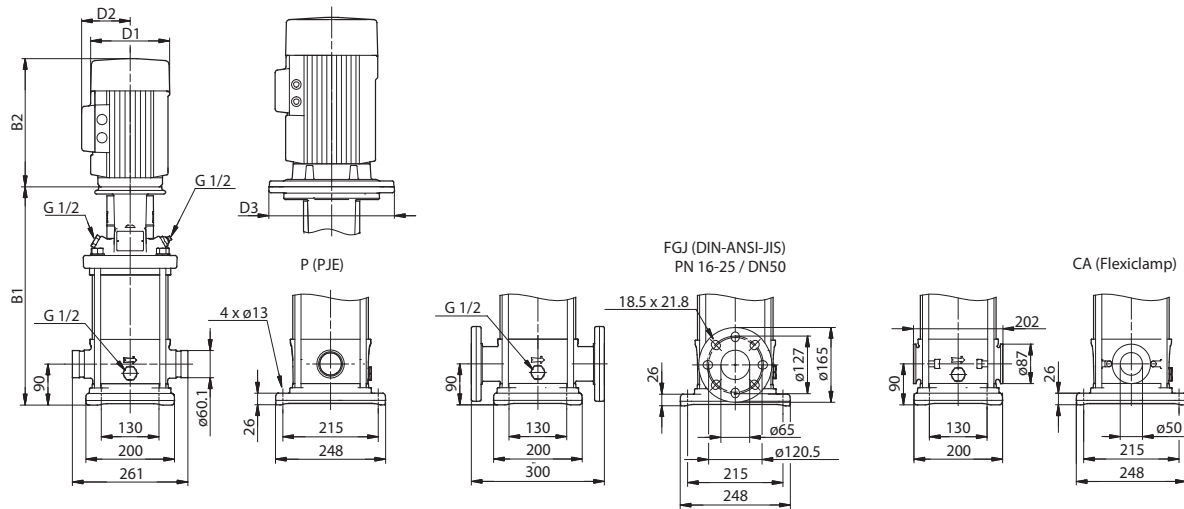

Dimensions and weights

Pump type	Motor P ₂ [kW]	CRI/CRN								
		Dimension [mm]							Net weight [kg]	
		PJE/CA		DIN flange		D1	D2	D3	PJE/CA	DIN flange
B1	B1+B2	B1	B1+B2							
CRI/CRN 20-1	1.10	397	648	397	648	141	109	-	34	39
CRI/CRN 20-2	2.20	413	734	413	734	178	110	-	42	47
CRI/CRN 20-3	4.00	463	835	463	835	220	134	-	59	64
CRI/CRN 20-4	5.50	540	931	540	931	220	134	300	81	86
CRI/CRN 20-5	5.50	585	976	585	976	220	134	300	82	87
CRI/CRN 20-6	7.50	630	1009	630	1009	260	159	300	94	99
CRI/CRN 20-7	7.50	675	1054	675	1054	260	159	300	96	101
CRI/CRN 20-8	11.00	797	1268	797	1268	314	204	350	138	143
CRI/CRN 20-10	11.00	887	1358	887	1358	314	204	350	142	147
CRI/CRN 20-12	15.00	977	1448	977	1448	314	204	350	158	163
CRI/CRN 20-14	15.00	1067	1538	1067	1538	314	204	350	162	166
CRI/CRN 20-17	18.50	1202	1717	1202	1717	314	204	350	180	184

CR 32

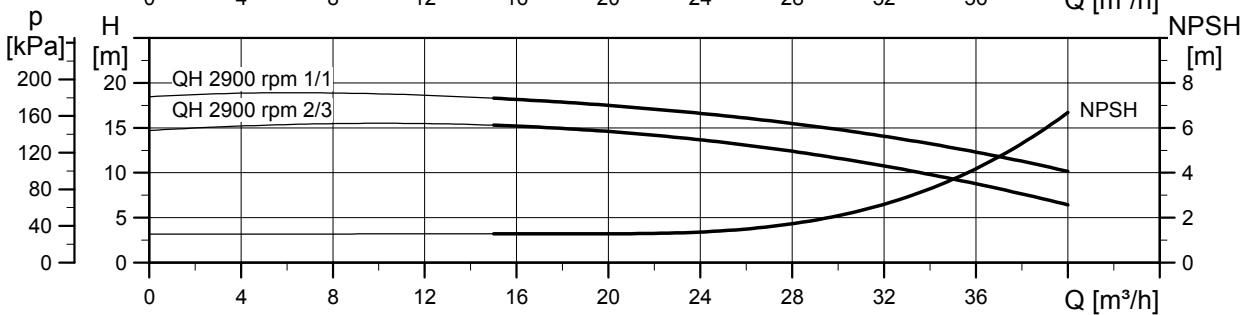
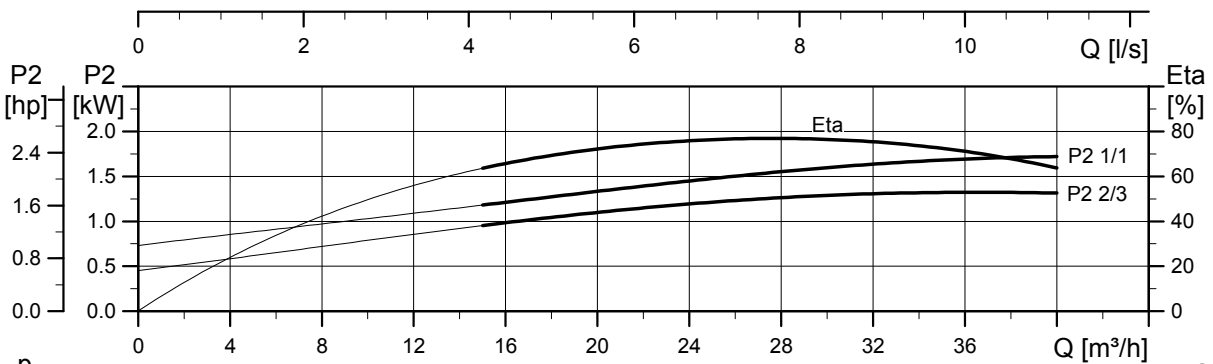
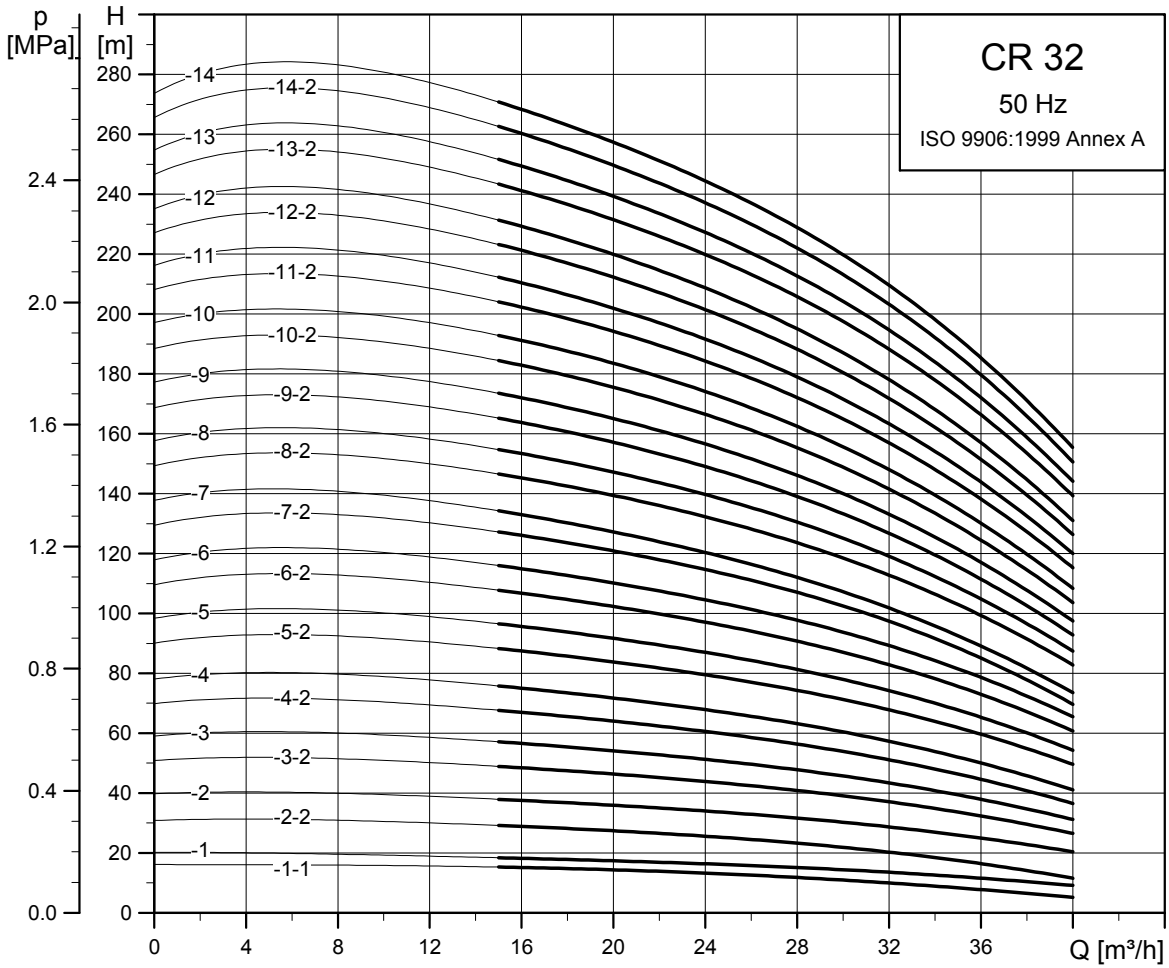

TM02 7302 1013

Dimensional sketch

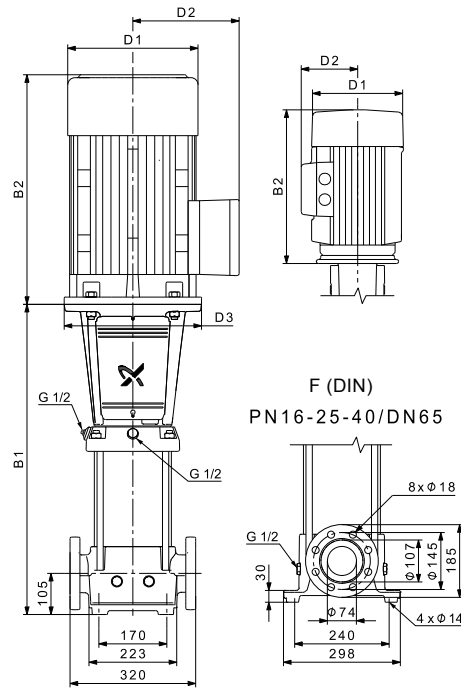

TM01 1749 3298

Dimensions and weights

Pump type	Motor P ₂ [kW]	CR					Net weight [kg]
		Dimension [mm]					
		B1	B1+B2	D1	D2	D3	
CR 32-1-1	1.50	505	786	178	110	-	64
CR 32-1	2.20	505	826	178	110	-	64
CR 32-2-2	3.00	575	910	198	120	-	73
CR 32-2	4.00	575	947	220	134	-	82
CR 32-3-2	5.50	645	1036	220	134	300	96
CR 32-3	5.50	645	1036	220	134	300	96
CR 32-4-2	7.50	715	1094	260	159	300	110
CR 32-4	7.50	715	1094	260	159	300	111
CR 32-5-2	11.00	895	1366	314	204	350	158
CR 32-5	11.00	895	1366	314	204	350	158
CR 32-6-2	11.00	965	1436	314	204	350	161
CR 32-6	11.00	965	1436	314	204	350	161
CR 32-7-2	15.00	1035	1506	314	204	350	177
CR 32-7	15.00	1035	1506	314	204	350	177
CR 32-8-2	15.00	1105	1576	314	204	350	183
CR 32-8	15.00	1105	1576	314	204	350	183
CR 32-9-2	18.50	1175	1690	314	204	350	200
CR 32-9	18.50	1175	1690	314	204	350	200
CR 32-10-2	18.50	1245	1760	314	204	350	203
CR 32-10	18.50	1245	1760	314	204	350	203
CR 32-11-2	22.00	1315	1856	314	204	350	220
CR 32-11	22.00	1315	1856	314	204	350	220
CR 32-12-2	22.00	1385	1926	314	204	350	224
CR 32-12	22.00	1385	1926	314	204	350	224
CR 32-13-2	30.00	1455	2066	396	315	400	344
CR 32-13	30.00	1455	2066	396	315	400	344
CR 32-14-2	30.00	1525	2136	396	315	400	347
CR 32-14	30.00	1525	2136	396	315	400	347

CRN 32

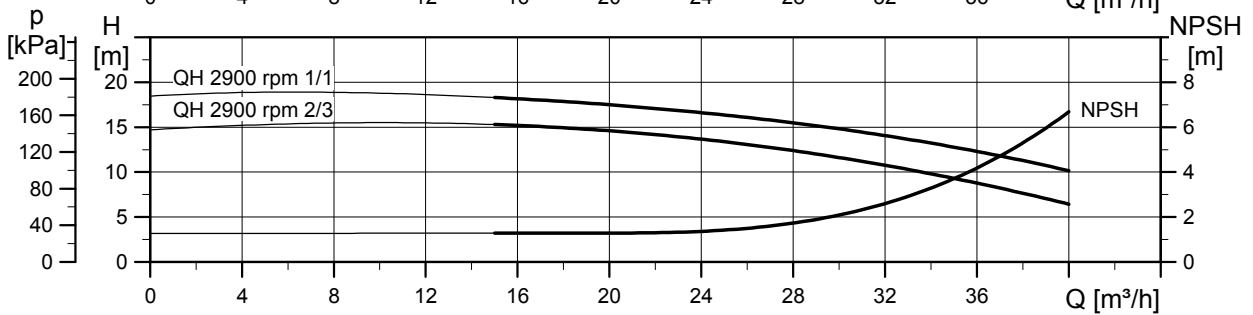
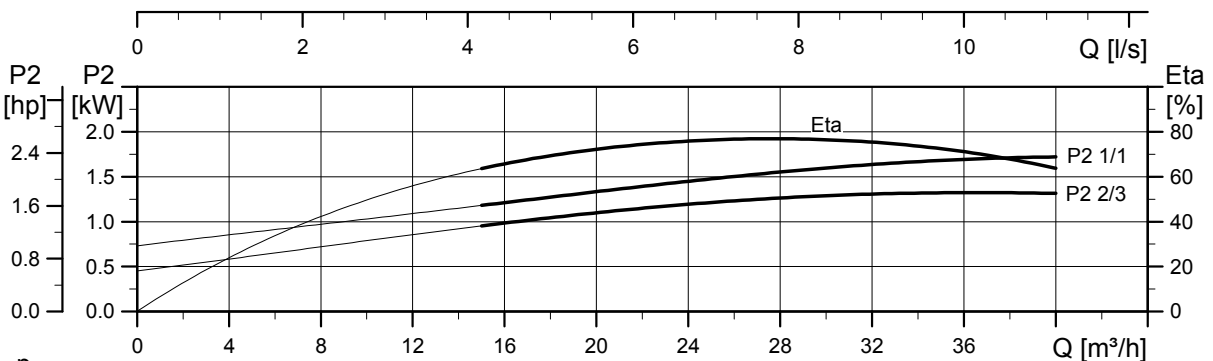
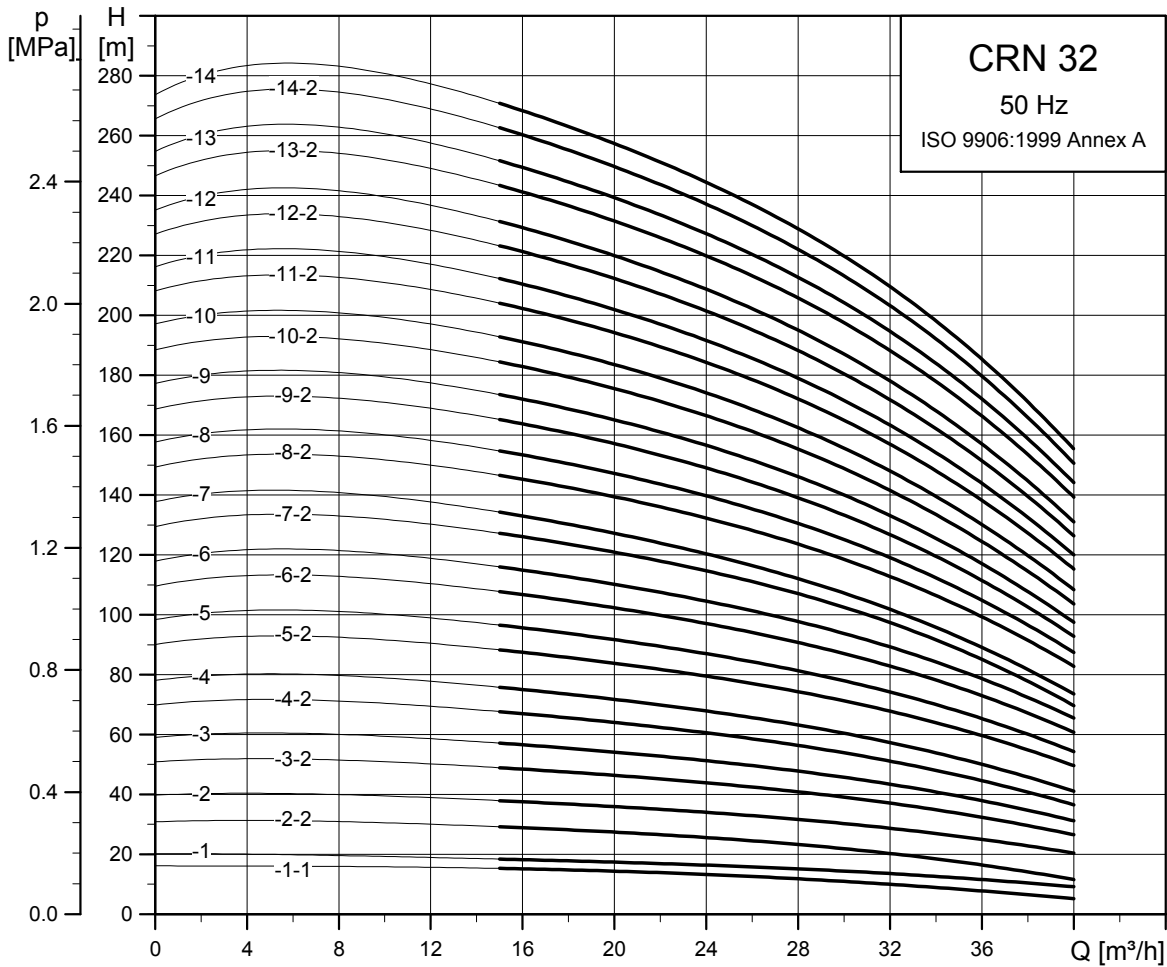

TM02 7303 1013

Dimensional sketch

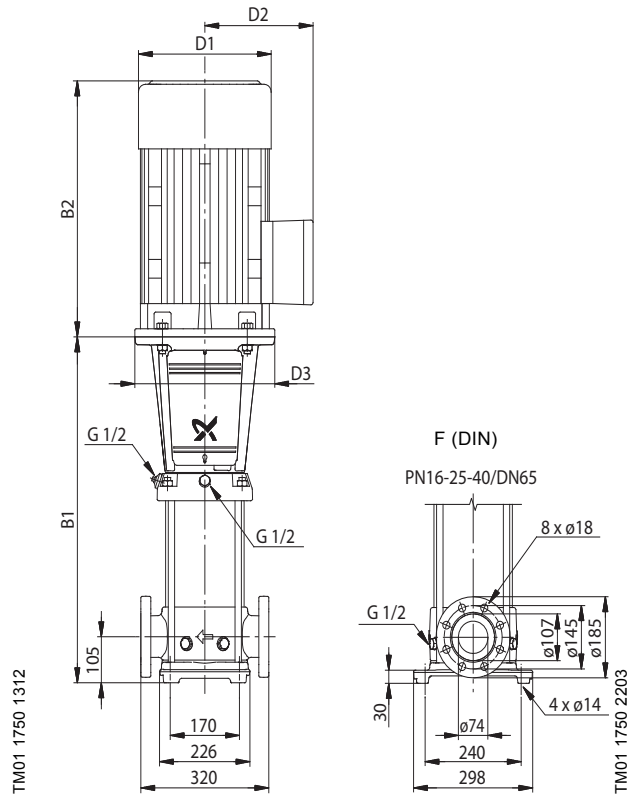
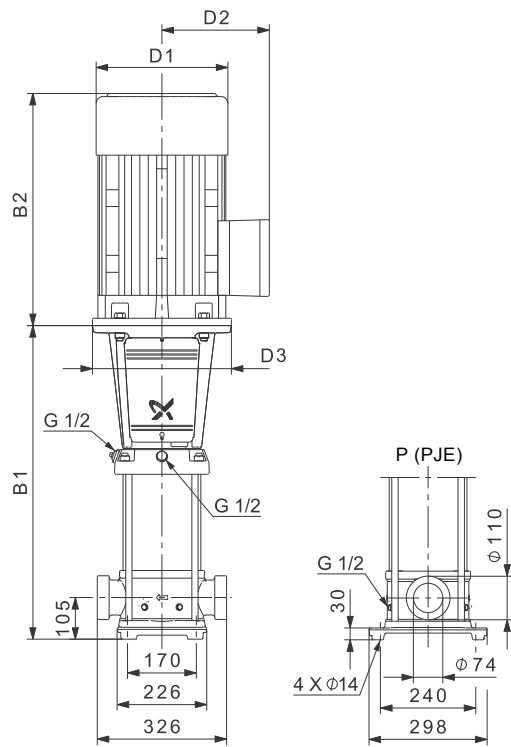

Dimensions and weights

Pump type	Motor P ₂ [kW]	CRN					Net weight [kg]
		B1	B1+B2	D1	D2	D3	
CRN 32-1-1	1.50	505	786	178	110	-	66
CRN 32-1	2.20	505	826	178	110	-	66
CRN 32-2-2	3.00	575	910	198	120	-	75
CRN 32-2	4.00	575	947	220	134	-	84
CRN 32-3-2	5.50	645	1036	220	134	300	99
CRN 32-3	5.50	645	1036	220	134	300	99
CRN 32-4-2	7.50	715	1094	260	159	300	112
CRN 32-4	7.50	715	1094	260	159	300	112
CRN 32-5-2	11.00	895	1366	314	204	350	160
CRN 32-5	11.00	895	1366	314	204	350	160
CRN 32-6-2	11.00	965	1436	314	204	350	163
CRN 32-6	11.00	965	1436	314	204	350	163
CRN 32-7-2	15.00	1035	1506	314	204	350	179
CRN 32-7	15.00	1035	1506	314	204	350	179
CRN 32-8-2	15.00	1105	1576	314	204	350	185
CRN 32-8	15.00	1105	1576	314	204	350	185
CRN 32-9-2	18.50	1175	1690	314	204	350	202
CRN 32-9	18.50	1175	1690	314	204	350	202
CRN 32-10-2	18.50	1245	1760	314	204	350	205
CRN 32-10	18.50	1245	1760	314	204	350	205
CRN 32-11-2	22.00	1315	1856	314	204	350	222
CRN 32-11	22.00	1315	1856	314	204	350	222
CRN 32-12-2	22.00	1385	1926	314	204	350	226
CRN 32-12	22.00	1385	1926	314	204	350	226
CRN 32-13-2	30.00	1455	2066	396	315	400	346
CRN 32-13	30.00	1455	2066	396	315	400	346
CRN 32-14-2	30.00	1525	2136	396	315	400	350
CRN 32-14	30.00	1525	2136	396	315	400	350

CR 45

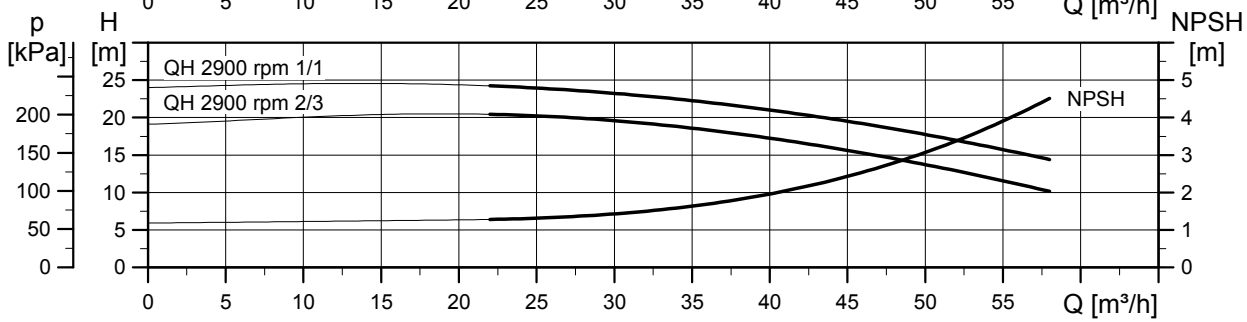
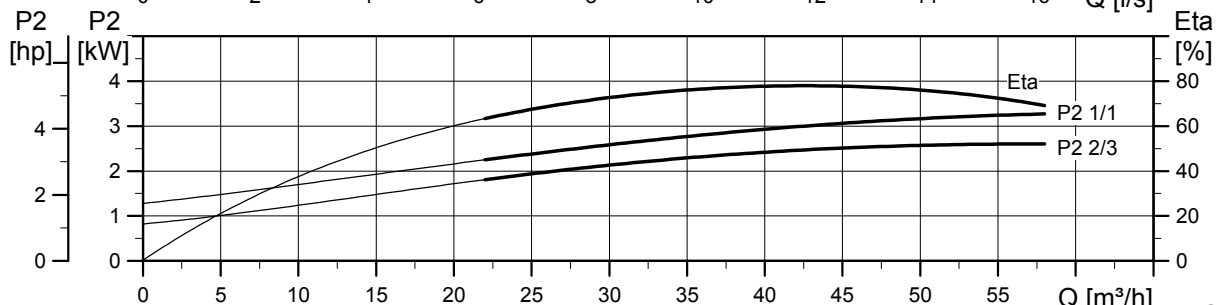
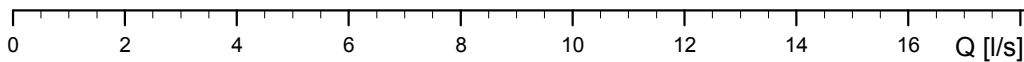
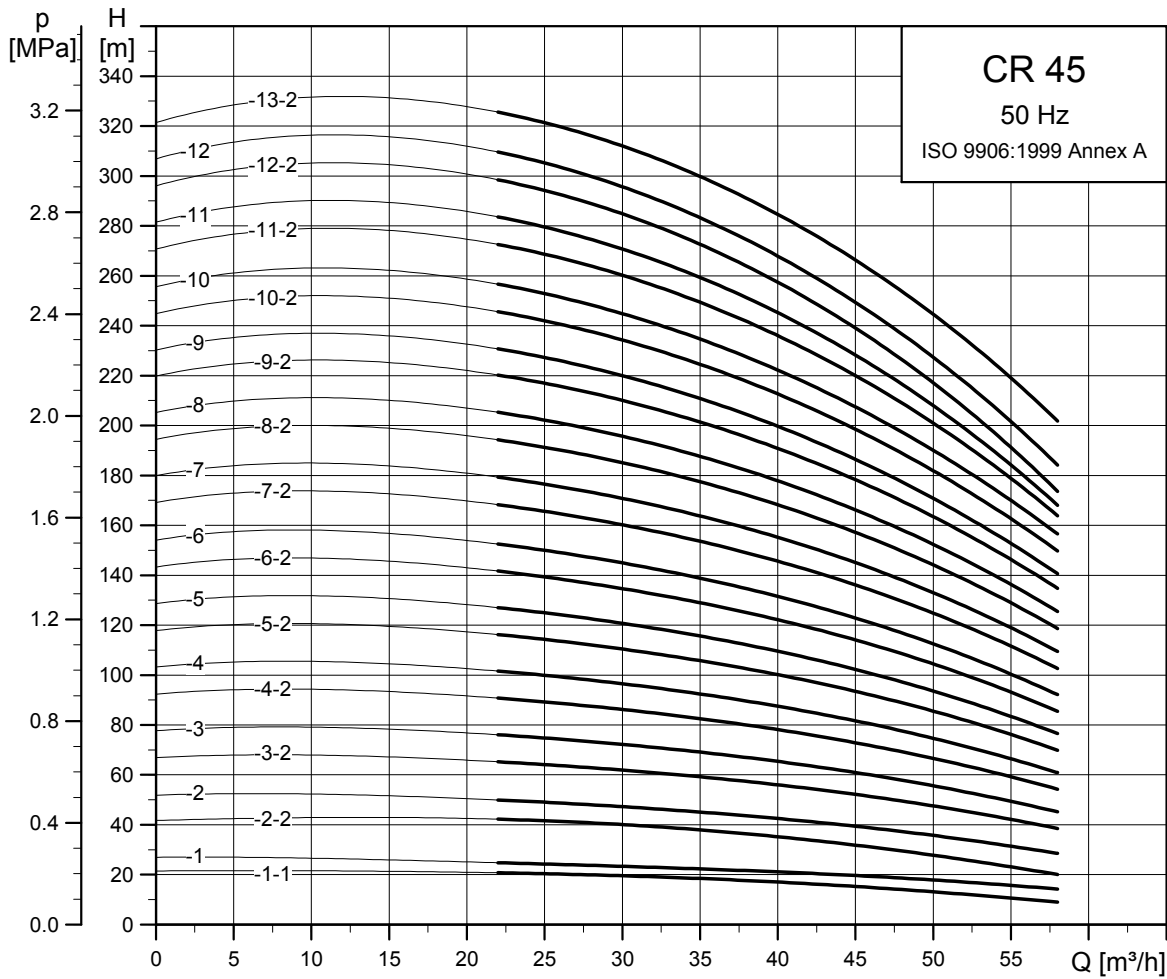

TM02 7304 1013

Dimensional sketch

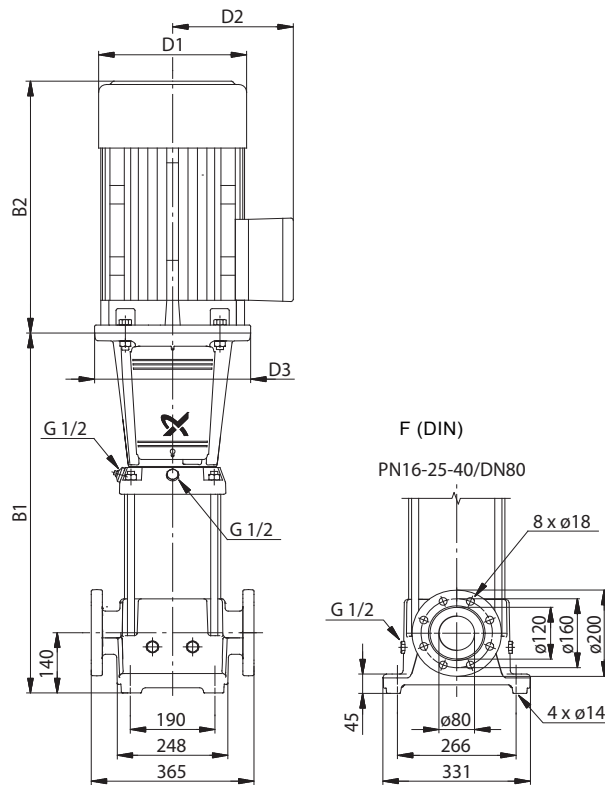

Dimensions and weights

Pump type	Motor P ₂ [kW]	CR					Net weight [kg]
		B1	B1+B2	D1	D2	D3	
CR 45-1-1	3.00	559	894	198	120	-	80
CR 45-1	4.00	559	931	220	134	-	89
CR 45-2-2	5.50	639	1030	220	134	300	104
CR 45-2	7.50	639	1018	260	159	300	114
CR 45-3-2	11.00	829	1300	314	204	350	163
CR 45-3	11.00	829	1300	314	204	350	163
CR 45-4-2	15.00	909	1380	314	204	350	180
CR 45-4	15.00	909	1380	314	204	350	180
CR 45-5-2	18.50	989	1504	314	204	350	197
CR 45-5	18.50	989	1504	314	204	350	197
CR 45-6-2	22.00	1069	1610	314	204	350	217
CR 45-6	22.00	1069	1610	314	204	350	217
CR 45-7-2	30.00	1149	1760	396	315	400	339
CR 45-7	30.00	1149	1760	396	315	400	339
CR 45-8-2	30.00	1229	1840	396	315	400	343
CR 45-8	30.00	1229	1840	396	315	400	343
CR 45-9-2	30.00	1309	1920	396	315	400	347
CR 45-9	37.00	1309	1945	396	315	400	362
CR 45-10-2	37.00	1389	2025	396	315	400	367
CR 45-10	37.00	1389	2025	396	315	400	367
CR 45-11-2	45.00	1469	2177	439	338	450	455
CR 45-11	45.00	1469	2177	439	338	450	455
CR 45-12-2	45.00	1549	2257	439	338	450	460
CR 45-12	45.00	1549	2257	439	338	450	460
CR 45-13-2	45.00	1629	2337	439	338	450	464

TM01 1751 3203

CRN 45

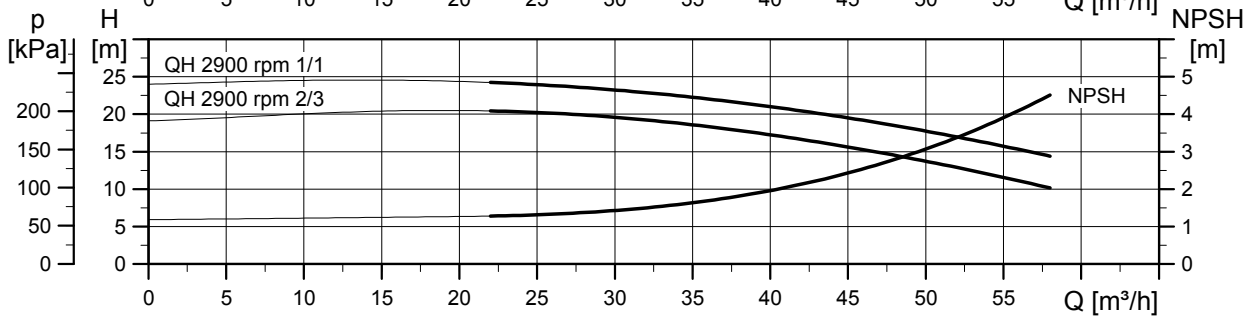
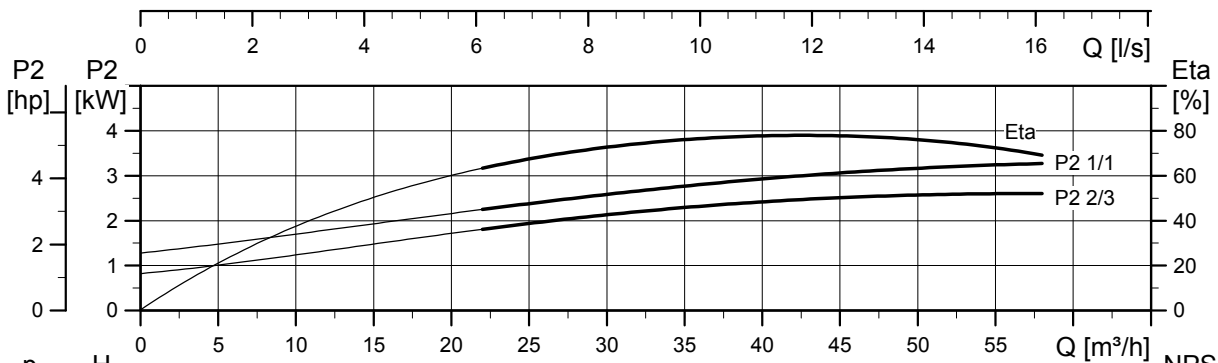
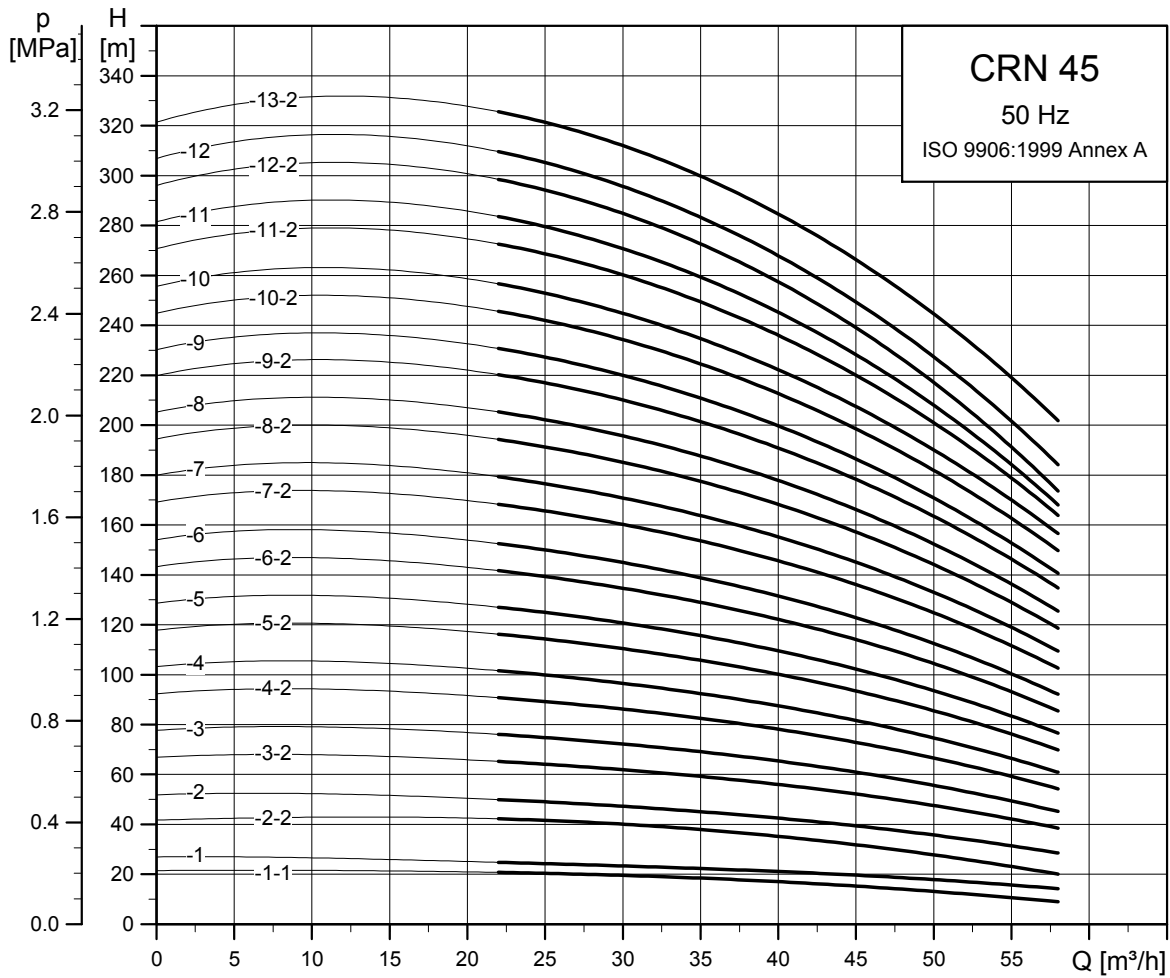

TM02 7305 1013

Dimensional sketch

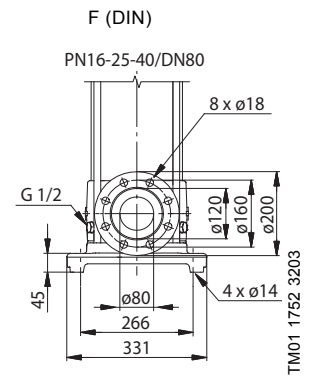
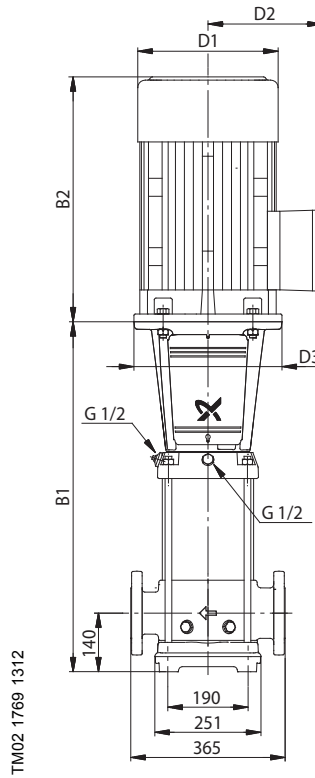
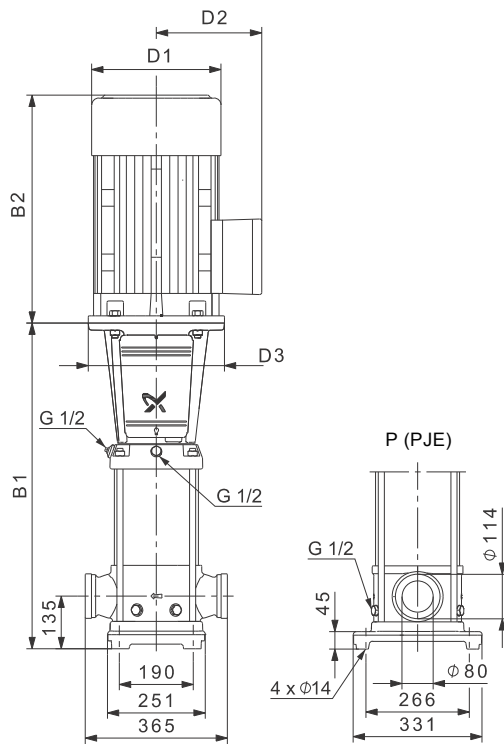

Dimensions and weights

Pump type	Motor P ₂ [kW]	CRN					Net weight [kg]
		Dimension [mm]					
		B1	B1+B2	D1	D2	D3	
CRN 45-1-1	3.00	559	894	198	120	-	80
CRN 45-1	4.00	559	931	220	134	-	89
CRN 45-2-2	5.50	639	1030	220	134	300	104
CRN 45-2	7.50	639	1018	260	159	300	114
CRN 45-3-2	11.00	829	1300	314	204	350	164
CRN 45-3	11.00	829	1300	314	204	350	164
CRN 45-4-2	15.00	909	1380	314	204	350	180
CRN 45-4	15.00	909	1380	314	204	350	180
CRN 45-5-2	18.50	989	1504	314	204	350	197
CRN 45-5	18.50	989	1504	314	204	350	197
CRN 45-6-2	22.00	1069	1610	314	204	350	218
CRN 45-6	22.00	1069	1610	314	204	350	218
CRN 45-7-2	30.00	1149	1760	396	315	400	339
CRN 45-7	30.00	1149	1760	396	315	400	339
CRN 45-8-2	30.00	1229	1840	396	315	400	343
CRN 45-8	30.00	1229	1840	396	315	400	343
CRN 45-9-2	30.00	1309	1920	396	315	400	348
CRN 45-9	37.00	1309	1945	396	315	400	363
CRN 45-10-2	37.00	1389	2025	396	315	400	367
CRN 45-10	37.00	1389	2025	396	315	400	367
CRN 45-11-2	45.00	1469	2177	439	338	450	455
CRN 45-11	45.00	1469	2177	439	338	450	455
CRN 45-12-2	45.00	1549	2257	439	338	450	460
CRN 45-12	45.00	1549	2257	439	338	450	460
CRN 45-13-2	45.00	1629	2337	439	338	450	464

CR 64

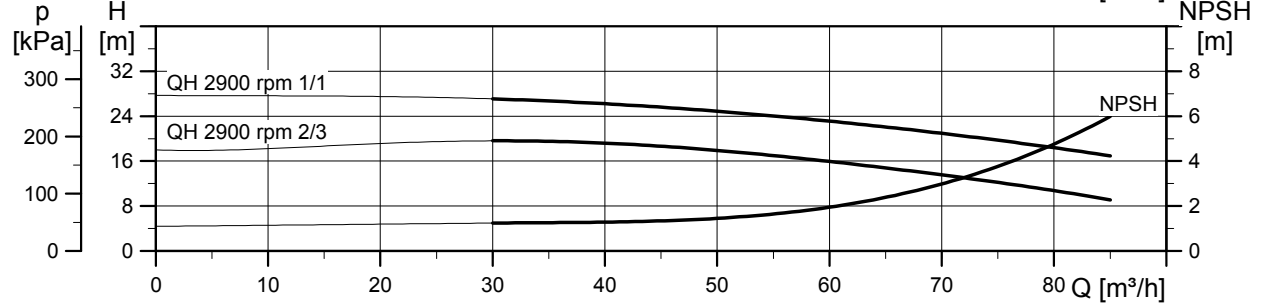
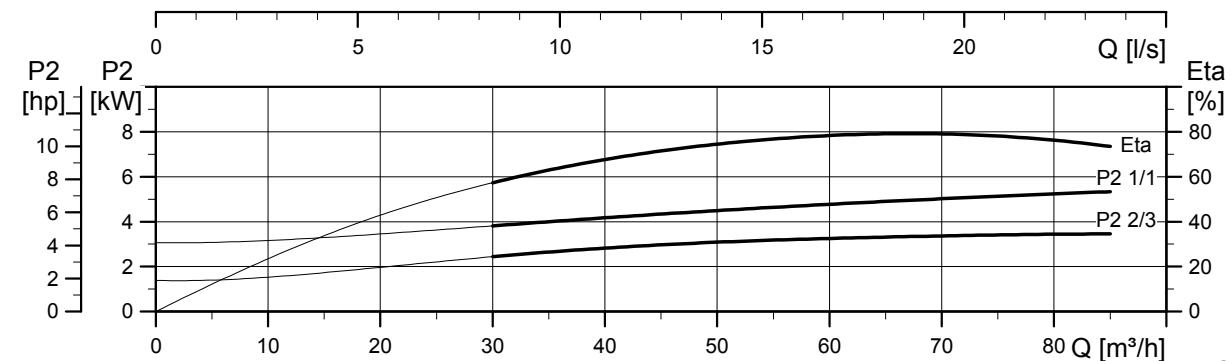
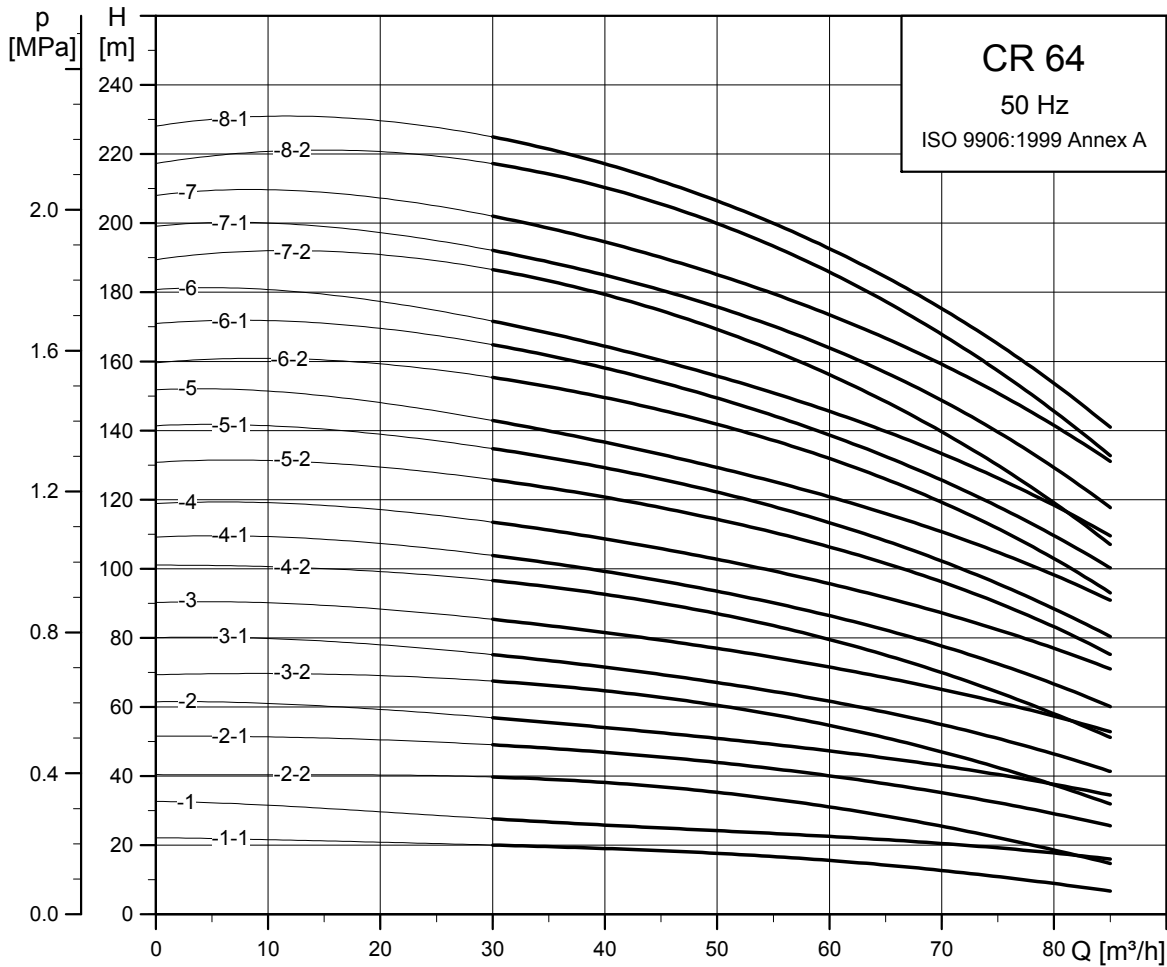

TM02 7306 1013

Dimensional sketch

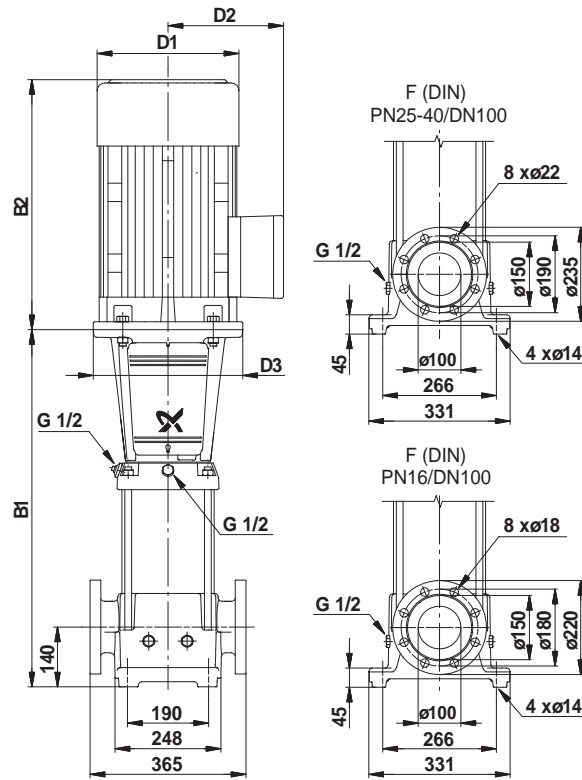

TM01 1753 5197

Dimensions and weights

Pump type	Motor P ₂ [kW]	CR					Net weight [kg]
		Dimension [mm]					
		B1	B1+B2	D1	D2	D3	
CR 64-1-1	4.00	561	933	220	134	-	91
CR 64-1	5.50	561	952	220	134	300	102
CR 64-2-2	7.50	644	1023	260	159	300	117
CR 64-2-1	11.00	754	1225	314	204	350	162
CR 64-2	11.00	754	1225	314	204	350	162
CR 64-3-2	15.00	836	1307	314	204	350	180
CR 64-3-1	15.00	836	1307	314	204	350	180
CR 64-3	18.50	836	1351	314	204	350	193
CR 64-4-2	18.50	919	1434	314	204	350	197
CR 64-4-1	22.00	919	1460	314	204	350	211
CR 64-4	22.00	919	1460	314	204	350	211
CR 64-5-2	30.00	1001	1612	396	315	400	333
CR 64-5-1	30.00	1001	1612	396	315	400	333
CR 64-5	30.00	1001	1612	396	315	400	333
CR 64-6-2	30.00	1084	1695	396	315	400	339
CR 64-6-1	37.00	1084	1720	396	315	400	354
CR 64-6	37.00	1084	1720	396	315	400	354
CR 64-7-2	37.00	1166	1802	396	315	400	359
CR 64-7-1	37.00	1166	1802	396	315	400	359
CR 64-7	45.00	1166	1874	439	338	450	443
CR 64-8-2	45.00	1249	1957	439	338	450	448
CR 64-8-1	45.00	1249	1957	439	338	450	448

CRN 64

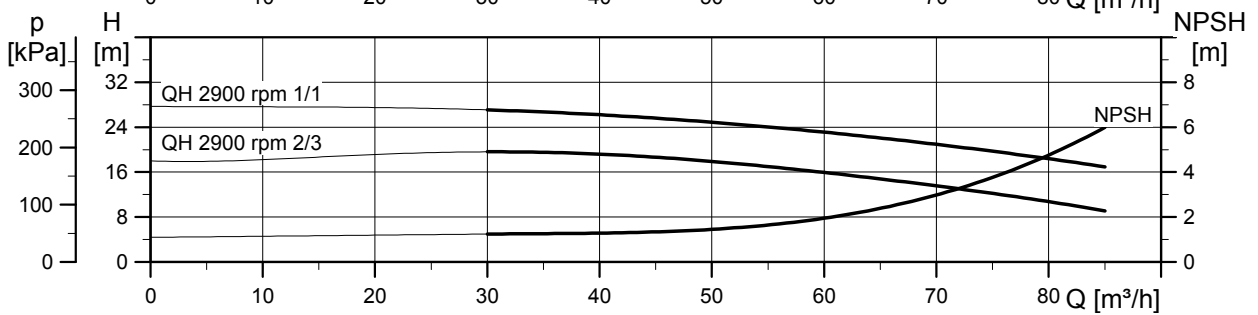
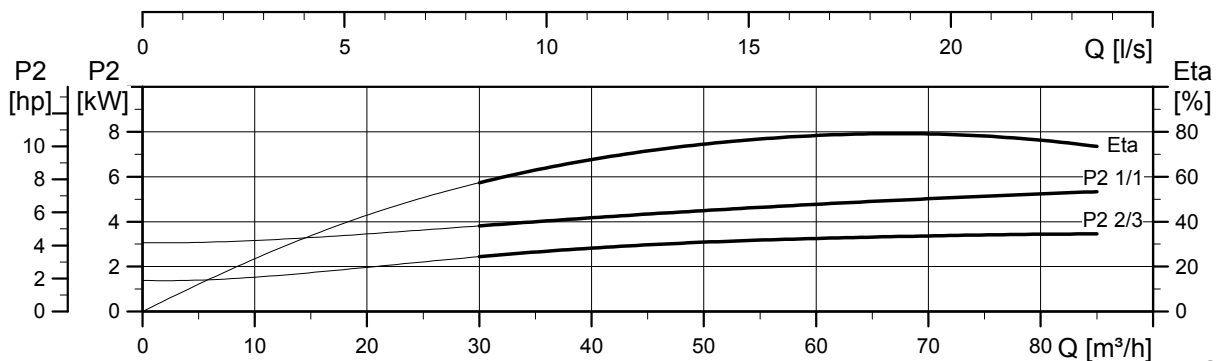
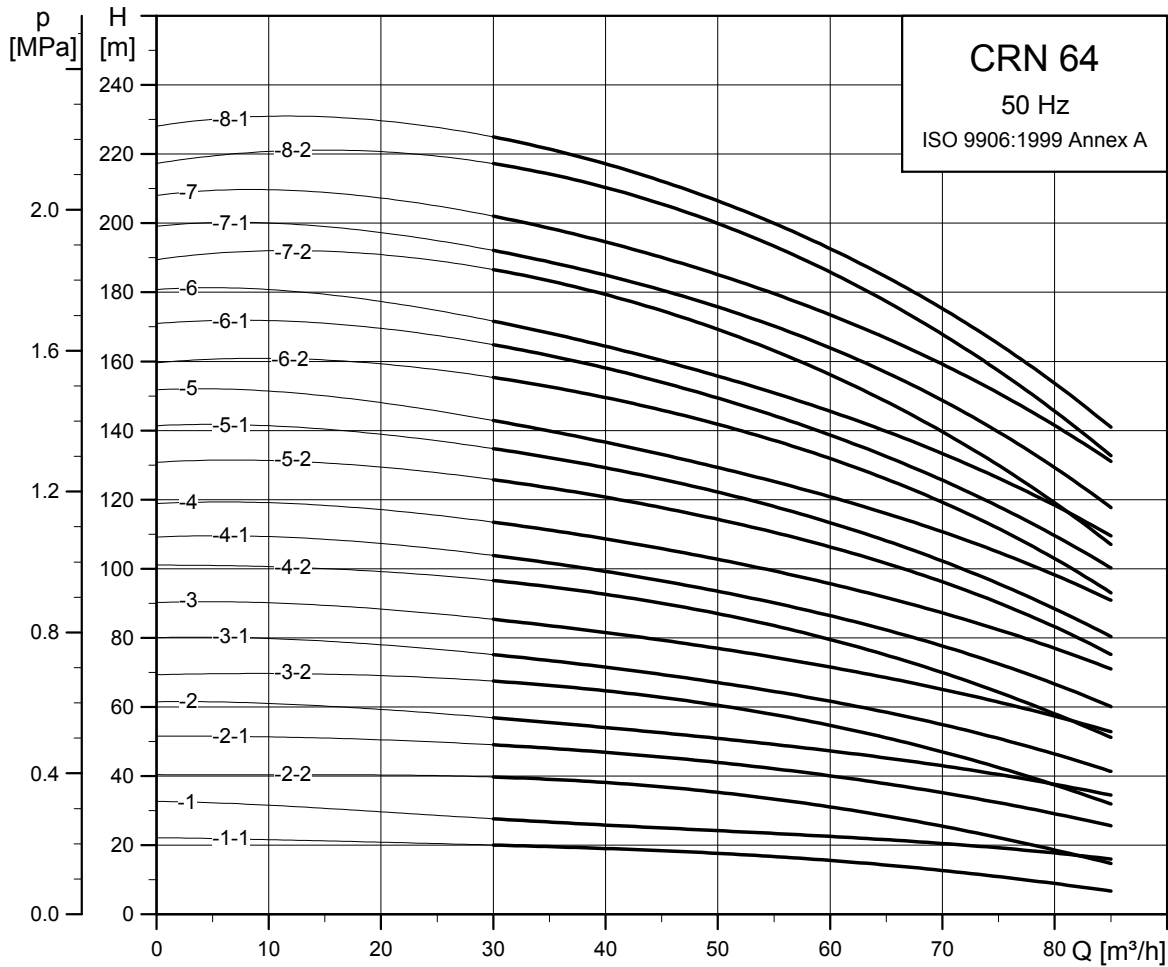

TM02 7307 1013

Dimensional sketch

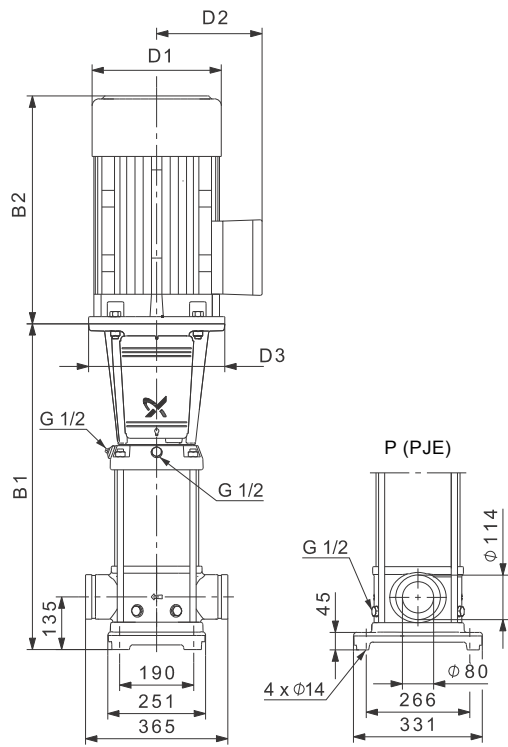

TM02 1771 1312

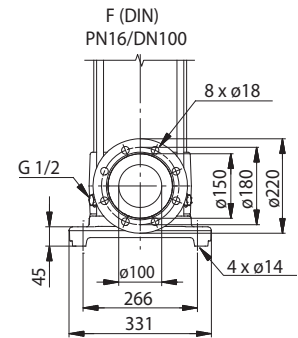
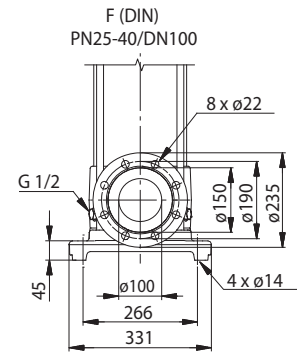
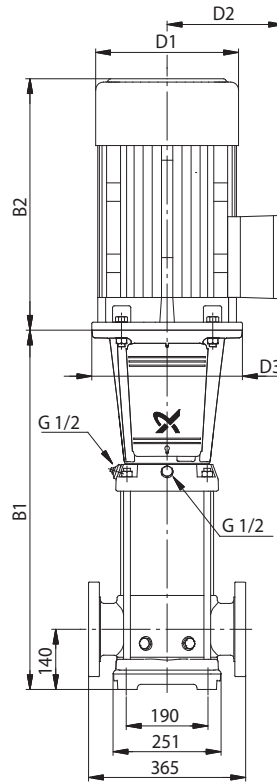

TM01 1754 0904

Dimensions and weights

Pump type	Motor P ₂ [kW]	CRN					Net weight [kg]
		Dimension [mm]					
		B1	B1+B2	D1	D2	D3	
CRN 64-1-1	4.00	561	933	220	134	-	91
CRN 64-1	5.50	561	952	220	134	300	102
CRN 64-2-2	7.50	644	1023	260	159	300	117
CRN 64-2-1	11.00	754	1225	314	204	350	162
CRN 64-2	11.00	754	1225	314	204	350	162
CRN 64-3-2	15.00	836	1307	314	204	350	180
CRN 64-3-1	15.00	836	1307	314	204	350	180
CRN 64-3	18.50	836	1351	314	204	350	193
CRN 64-4-2	18.50	919	1434	314	204	350	197
CRN 64-4-1	22.00	919	1460	314	204	350	211
CRN 64-4	22.00	919	1460	314	204	350	211
CRN 64-5-2	30.00	1001	1612	396	315	400	333
CRN 64-5-1	30.00	1001	1612	396	315	400	333
CRN 64-5	30.00	1001	1612	396	315	400	333
CRN 64-6-2	30.00	1084	1695	396	315	400	340
CRN 64-6-1	37.00	1084	1720	396	315	400	355
CRN 64-6	37.00	1084	1720	396	315	400	355
CRN 64-7-2	37.00	1166	1802	396	315	400	359
CRN 64-7-1	37.00	1166	1802	396	315	400	359
CRN 64-7	45.00	1166	1874	439	338	450	444
CRN 64-8-2	45.00	1249	1957	439	338	450	448
CRN 64-8-1	45.00	1249	1957	439	338	450	448

CR 90

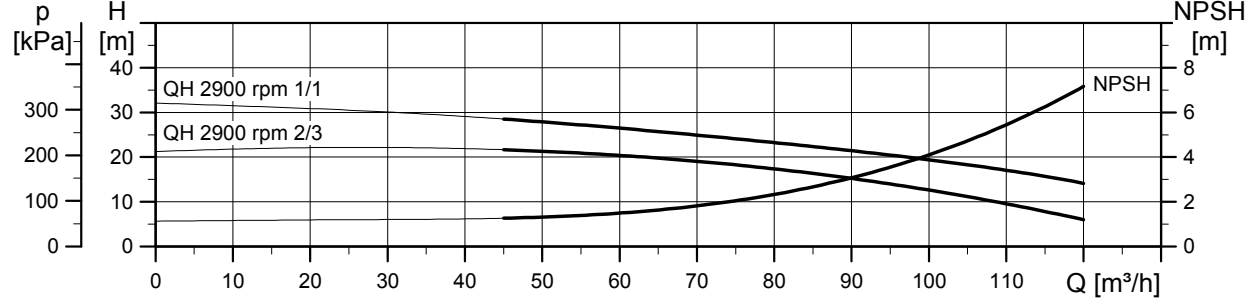
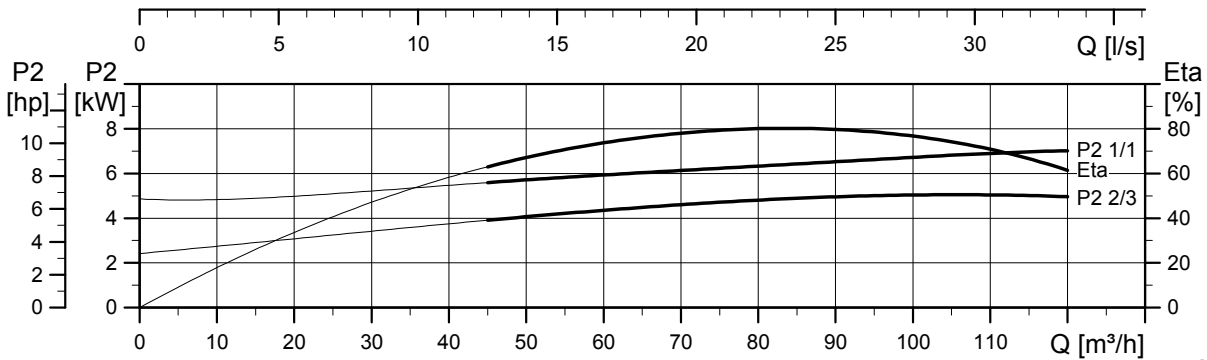
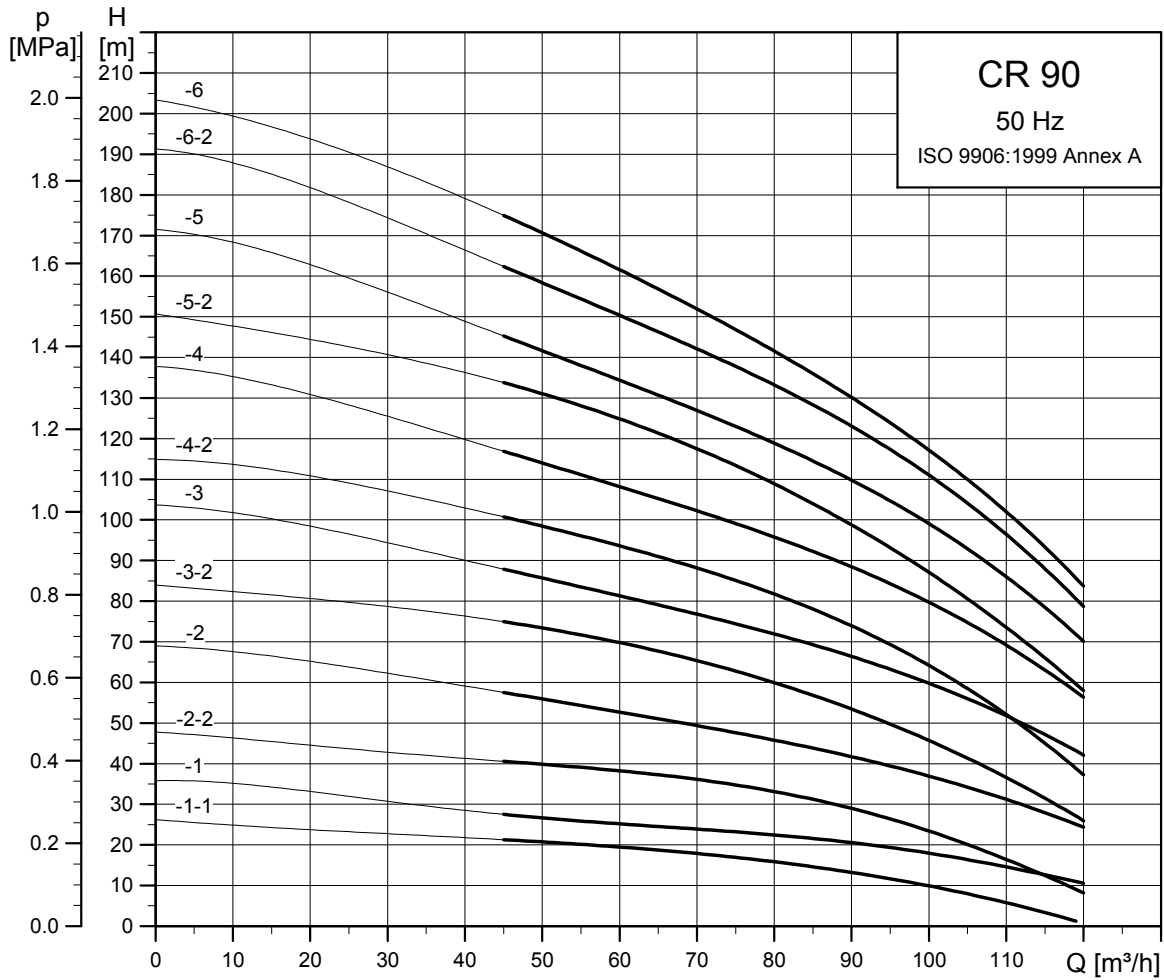

TM02 7308 1013

Dimensional sketch

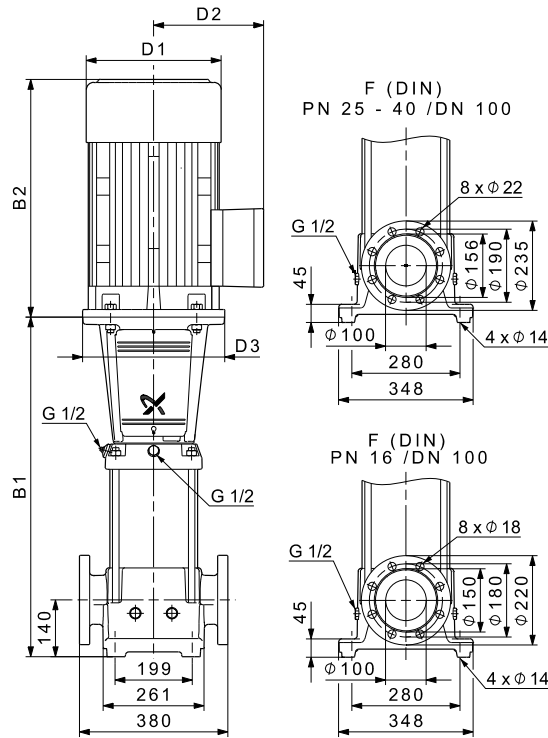

Dimensions and weights

Pump type	Motor P ₂ [kW]	CR					Net weight [kg]
		B1	B1+B2	D1	D2	D3	
CR 90-1-1	5.50	571	962	220	134	300	107
CR 90-1	7.50	571	950	260	159	300	117
CR 90-2-2	11.00	773	1244	314	204	350	168
CR 90-2	15.00	773	1244	314	204	350	181
CR 90-3-2	18.50	865	1380	314	204	350	199
CR 90-3	22.00	865	1406	314	204	350	212
CR 90-4-2	30.00	957	1568	396	315	400	335
CR 90-4	30.00	957	1568	396	315	400	335
CR 90-5-2	37.00	1049	1685	396	315	400	356
CR 90-5	37.00	1049	1685	396	315	400	356
CR 90-6-2	45.00	1141	1849	439	338	450	446
CR 90-6	45.00	1141	1849	439	338	450	446

TM01 1755 4809

CRN 90

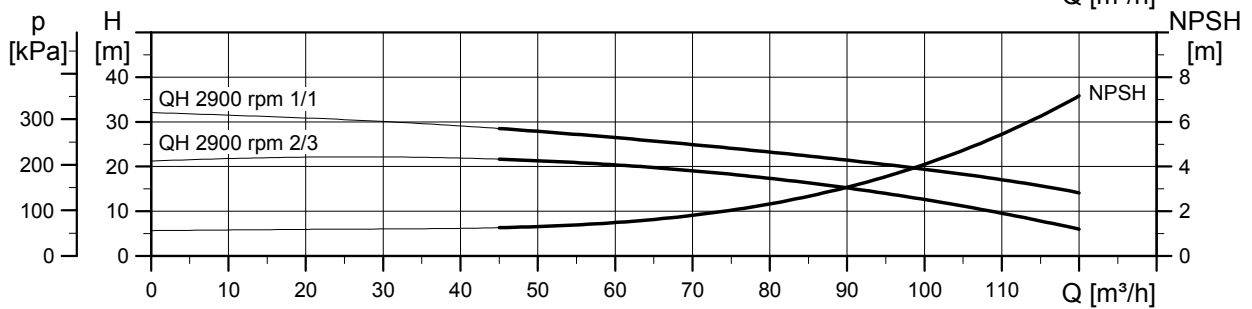
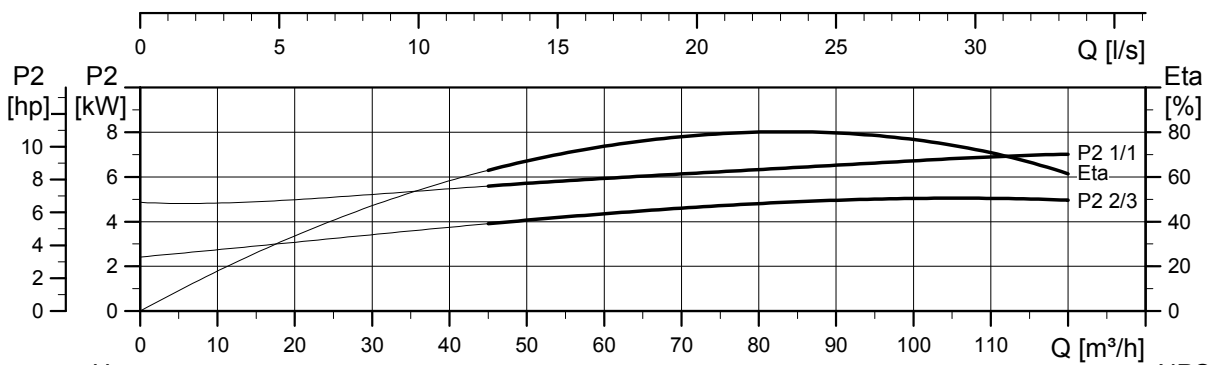
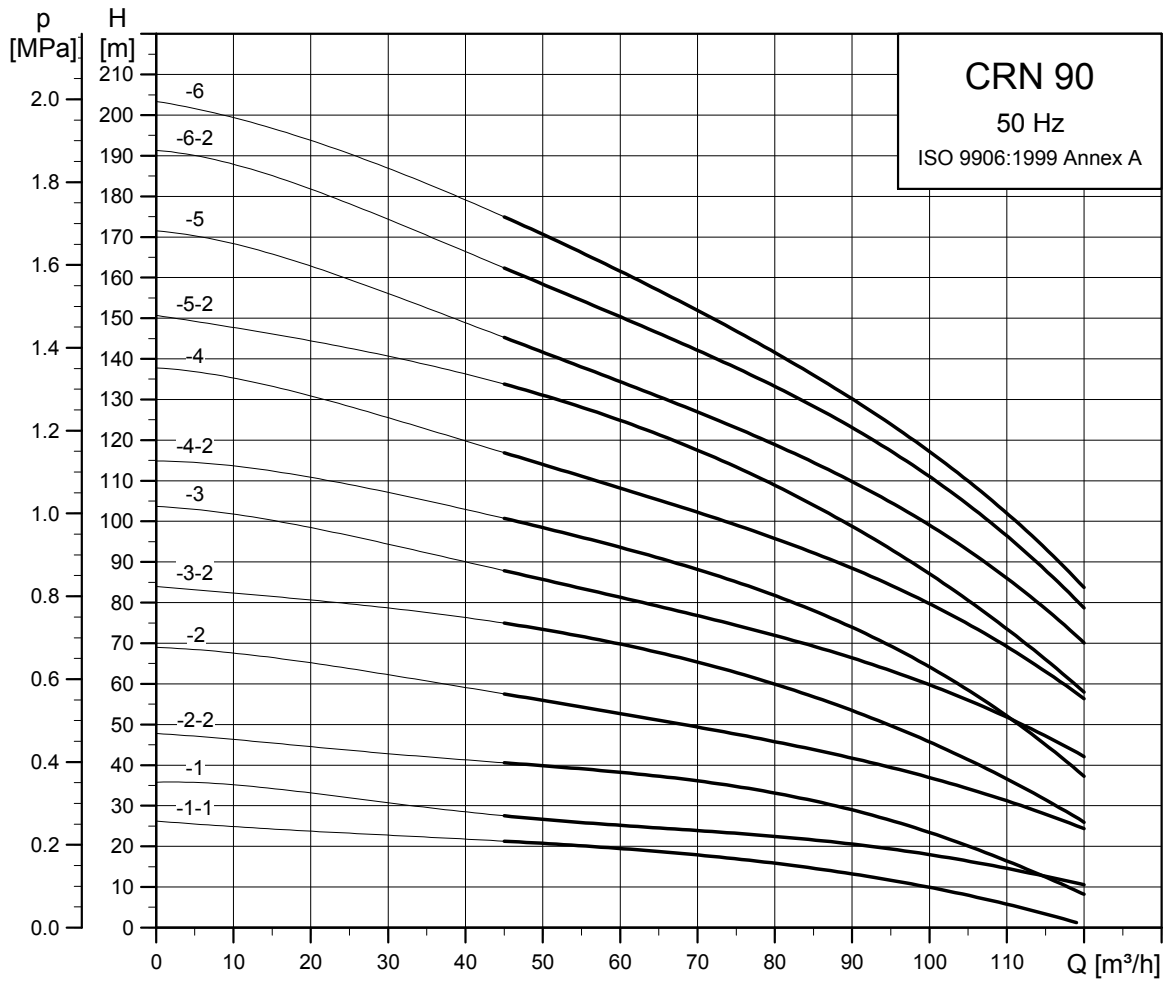

TM02 7309 1013

Dimensional sketch

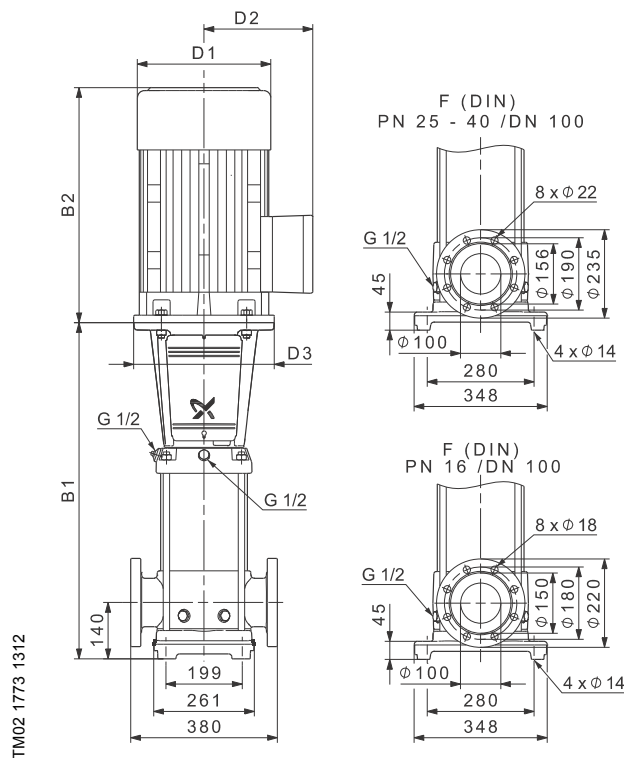
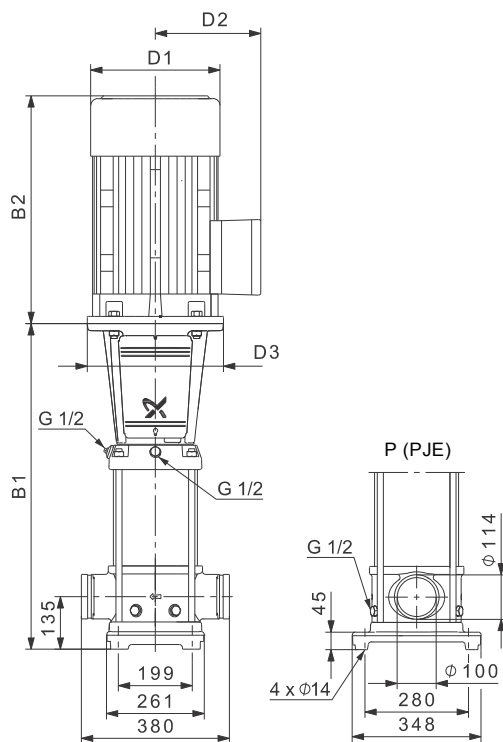

Dimensions and weights

Pump type	Motor P ₂ [kW]	CRN					Net weight [kg]
		B1	B1+B2	D1	D2	D3	
CRN 90-1-1	5.5	571	962	220	134	300	109
CRN 90-1	7.5	571	950	260	159	300	119
CRN 90-2-2	11	773	1244	314	204	350	169
CRN 90-2	15	773	1244	314	204	350	182
CRN 90-3-2	18.5	865	1380	314	204	350	200
CRN 90-3	22	865	1406	314	204	350	214
CRN 90-4-2	30	957	1568	396	315	400	336
CRN 90-4	30	957	1568	396	315	400	336
CRN 90-5-2	37	1049	1685	396	315	400	359
CRN 90-5	37	1049	1685	396	315	400	359
CRN 90-6-2	45	1141	1849	439	338	450	448
CRN 90-6	45	1141	1849	439	338	450	448

TM02 1570 4809

CR 120

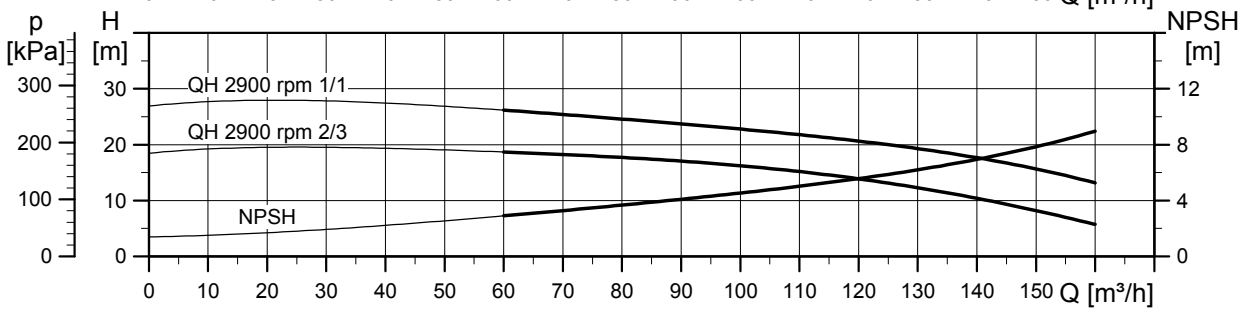
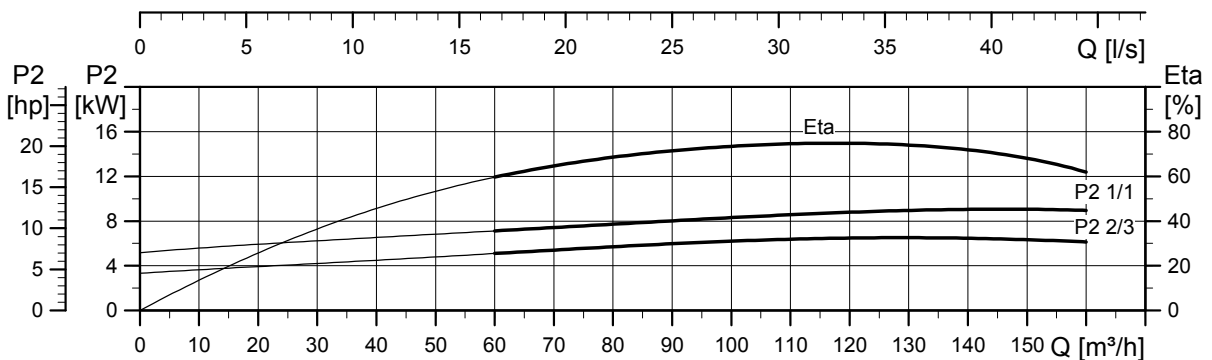
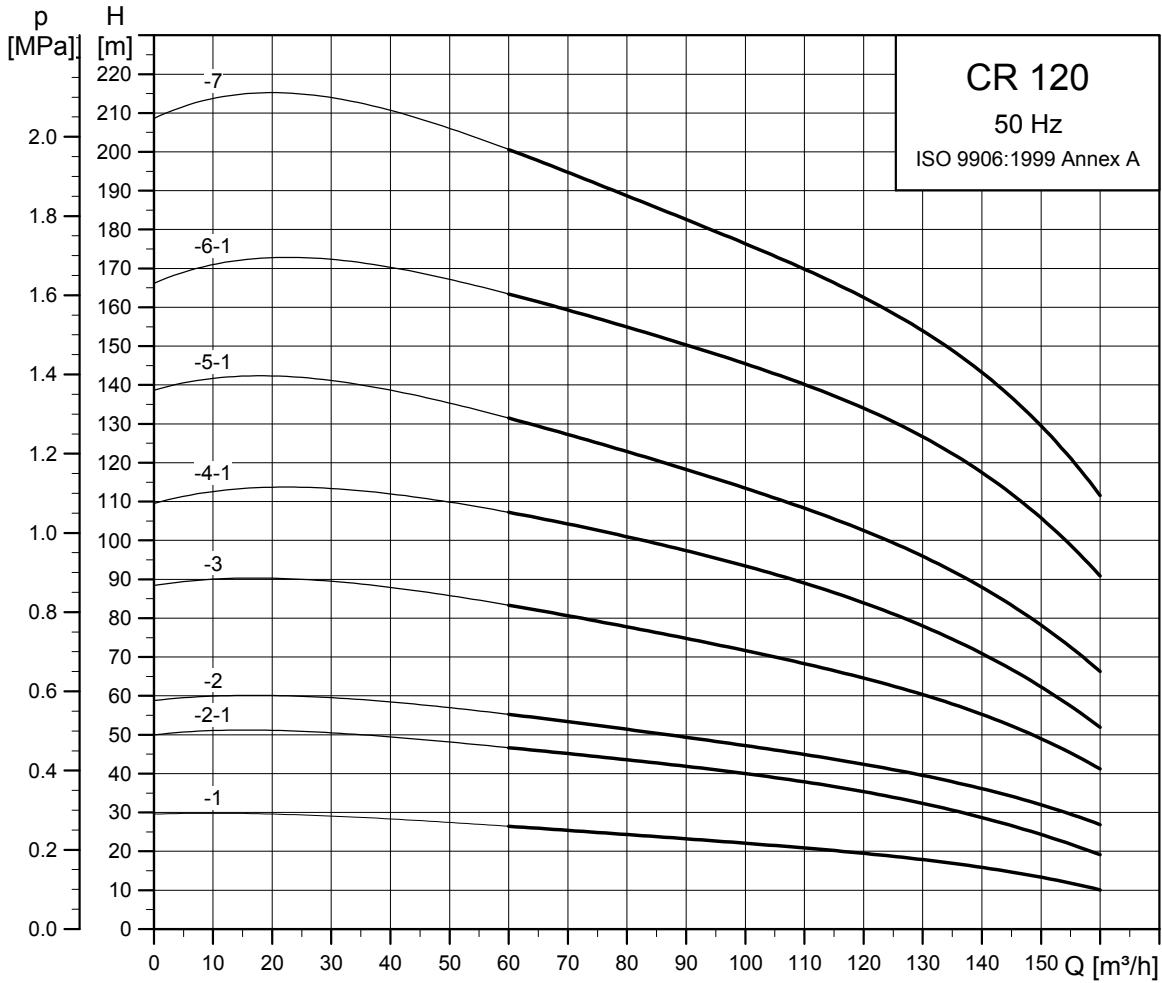

TM03 8743 1013

Dimensional sketch

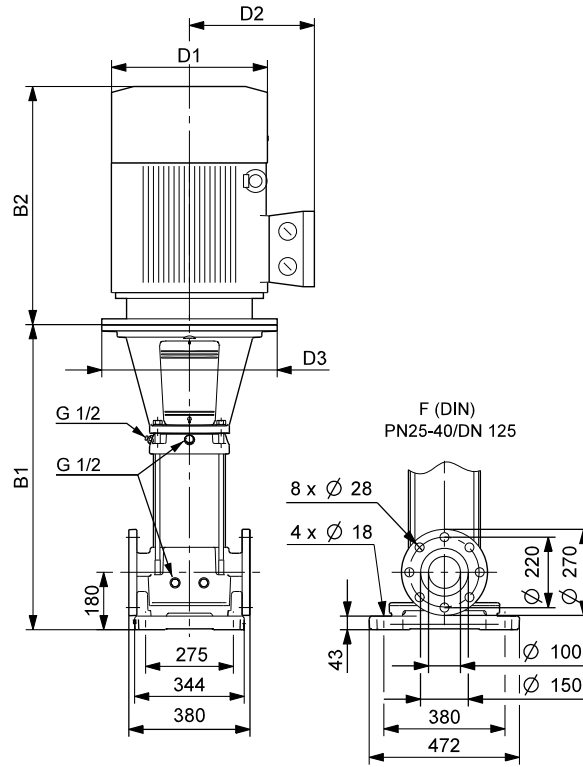

TM03 9704 4407

Dimensions and weights

Pump type	Motor P ₂ [kW]	CR					Net weight [kg]
		Dimension [mm]					
		B1	B1+B2	D1	D2	D3	
CR 120-1	11.00	834	1305	314	204	350	191
CR 120-2-1	18.50	990	1505	314	204	350	227
CR 120-2	22.00	990	1531	314	204	350	240
CR 120-3	30.00	1145	1756	396	315	400	368
CR 120-4-1	37.00	1301	1937	396	315	400	392
CR 120-5-1	45.00	1456	2164	439	338	450	487
CR 120-6-1	55.00	1642	2389	487	410	550	627
CR 120-7	75.00	1797	2617	540	433	550	741

CRN 120

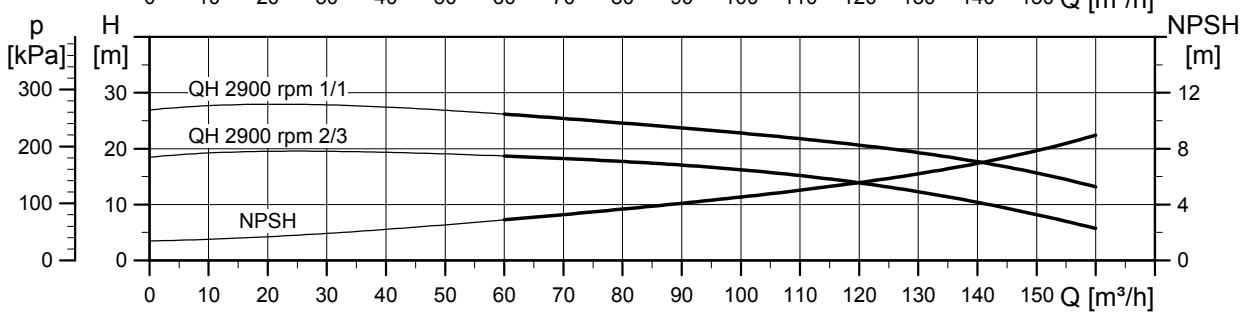
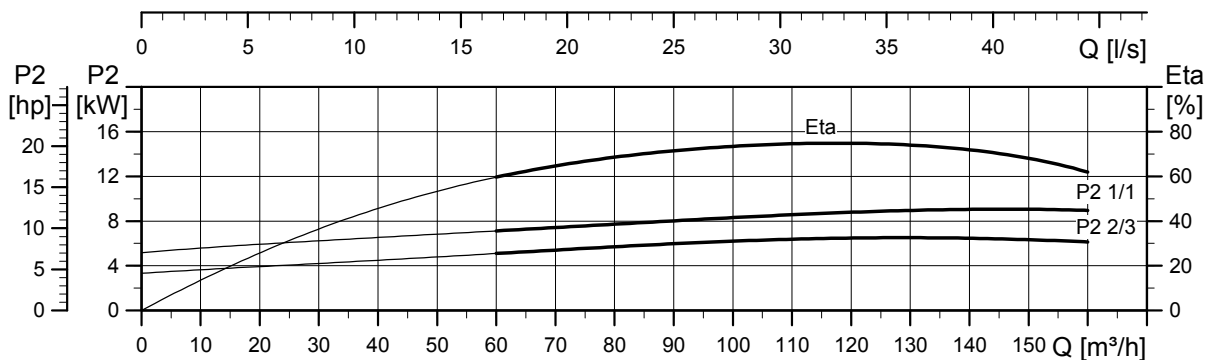
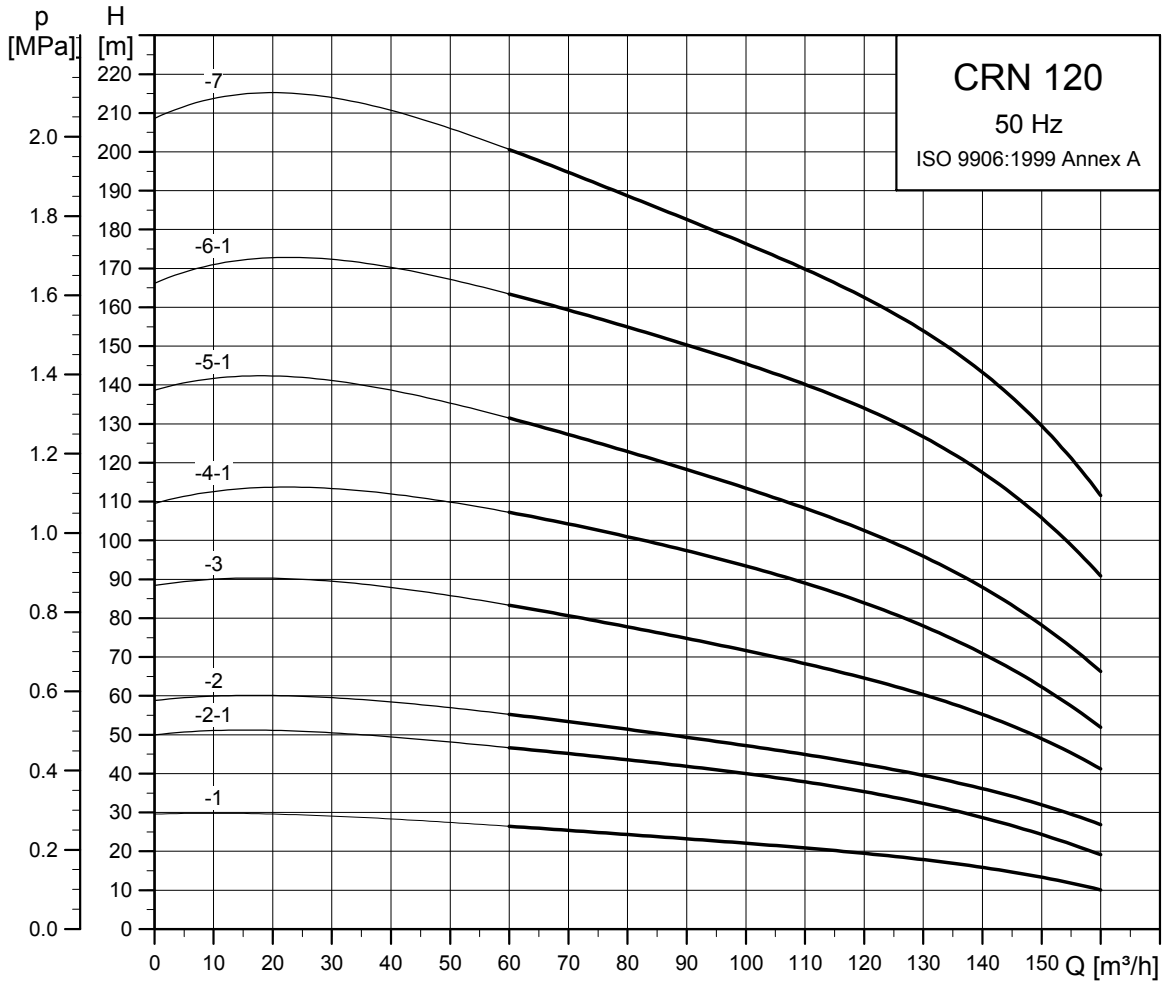

TM03 8744 1013

Dimensional sketch

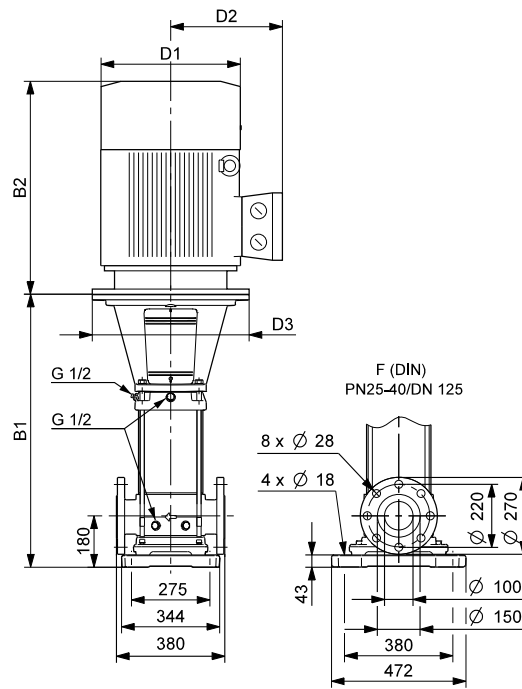

TM03 9705 2108

Dimensions and weights

Pump type	Motor P ₂ [kW]	CRN					Net weight [kg]
		Dimension [mm]					
		B1	B1+B2	D1	D2	D3	
CRN 120-1	11.00	834	1305	314	204	350	195
CRN 120-2-1	18.50	990	1505	314	204	350	231
CRN 120-2	22.00	990	1531	314	204	350	245
CRN 120-3	30.00	1145	1756	396	315	400	372
CRN 120-4-1	37.00	1301	1937	396	315	400	397
CRN 120-5-1	45.00	1456	2164	439	338	450	491
CRN 120-6-1	55.00	1642	2389	487	410	550	631
CRN 120-7	75.00	1797	2617	540	433	550	755

CR 150

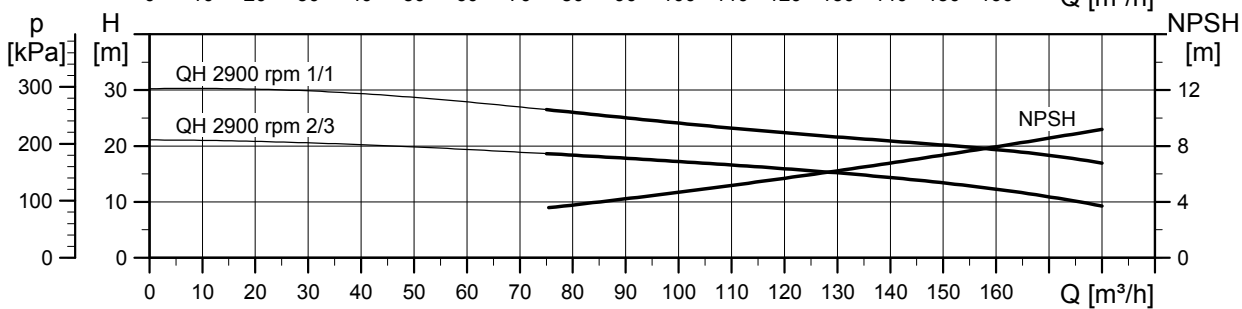
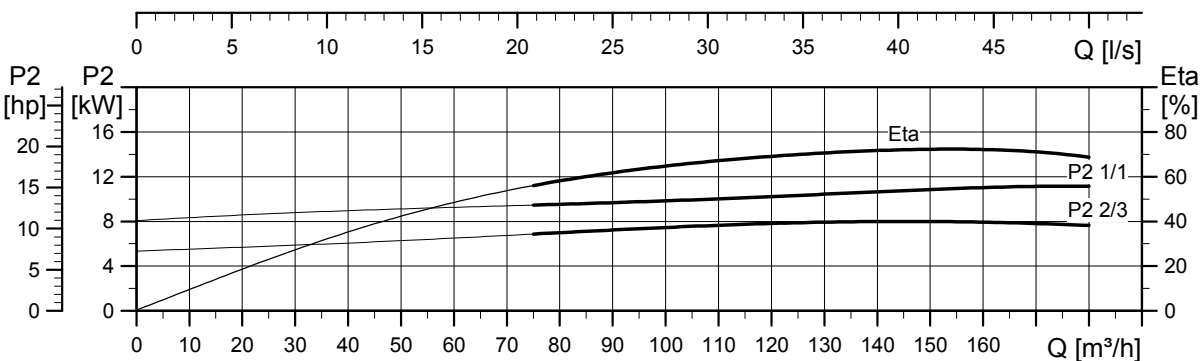
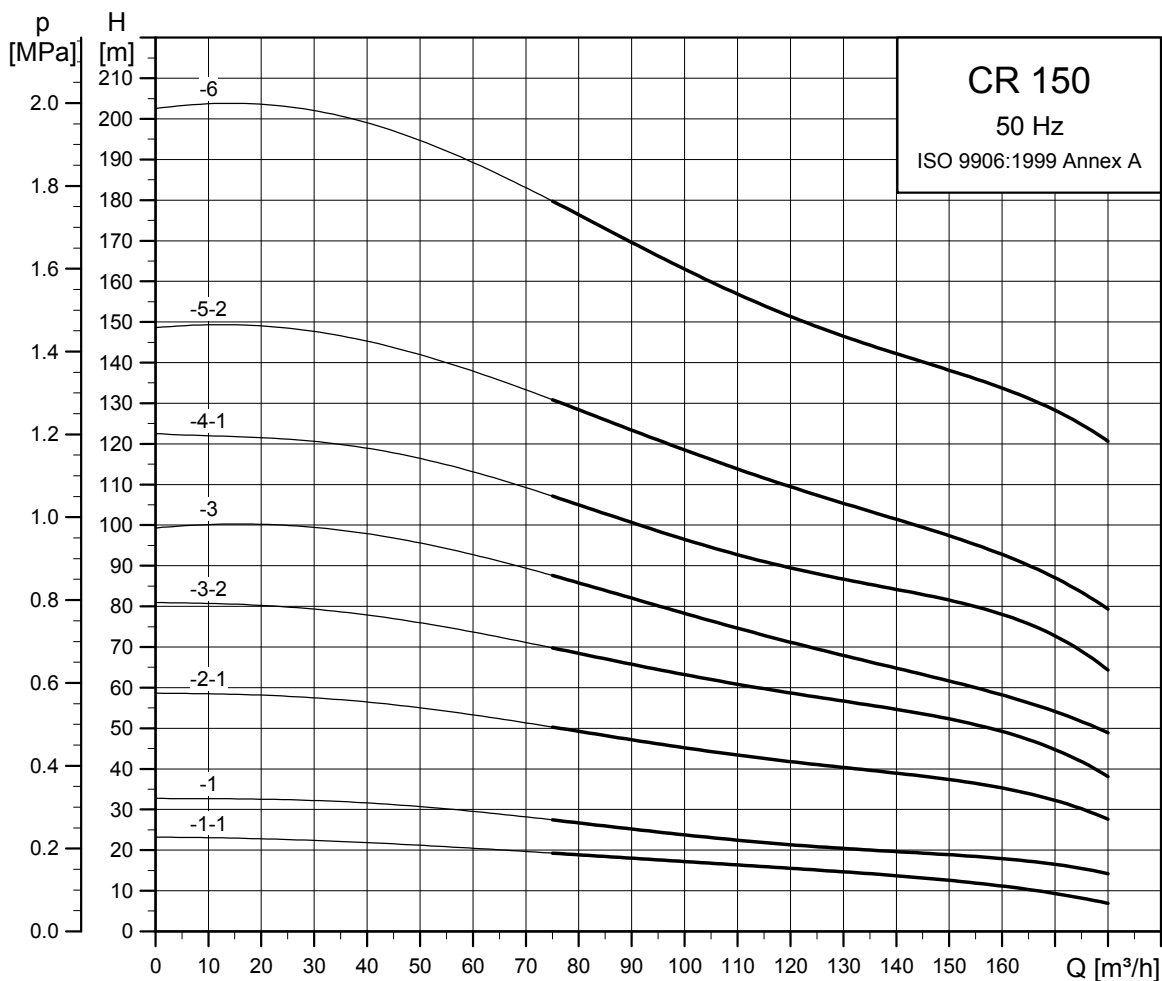

TM03 8745 3513

Dimensional sketch

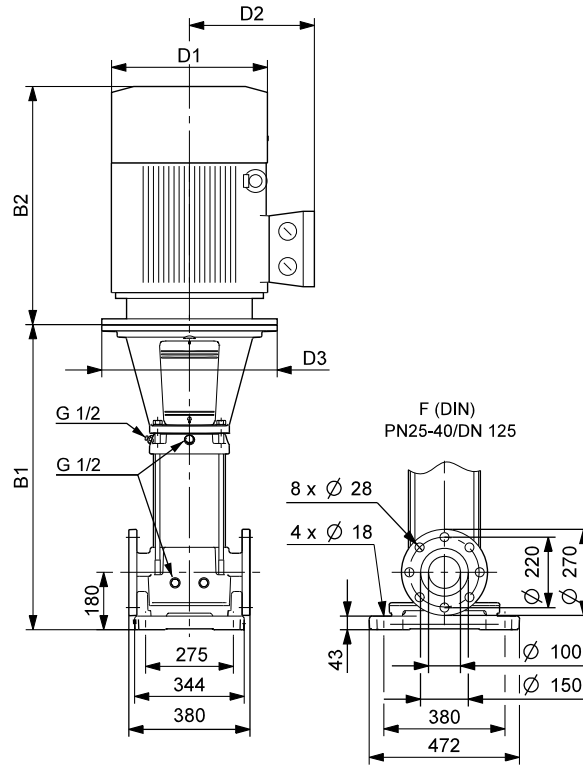

TM03 9704 4407

Dimensions and weights

Pump type	Motor P ₂ [kW]	CR					Net weight [kg]
		B1	B1+B2	D1	D2	D3	
CR 150-1-1	11.00	834	1305	314	204	350	191
CR 150-1	15.00	834	1305	314	204	350	204
CR 150-2-1	22.00	990	1531	314	204	350	241
CR 150-3-2	30.00	1145	1756	396	315	400	368
CR 150-3	37.00	1145	1781	396	315	400	383
CR 150-4-1	45.00	1301	2009	439	338	450	477
CR 150-5-2	55.00	1486	2233	487	410	550	617
CR 150-6	75.00	1642	2462	540	433	550	733

CRN 150

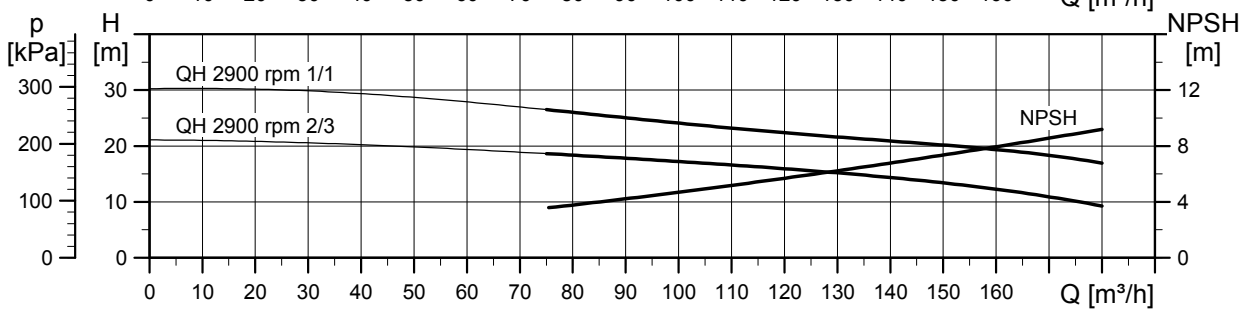
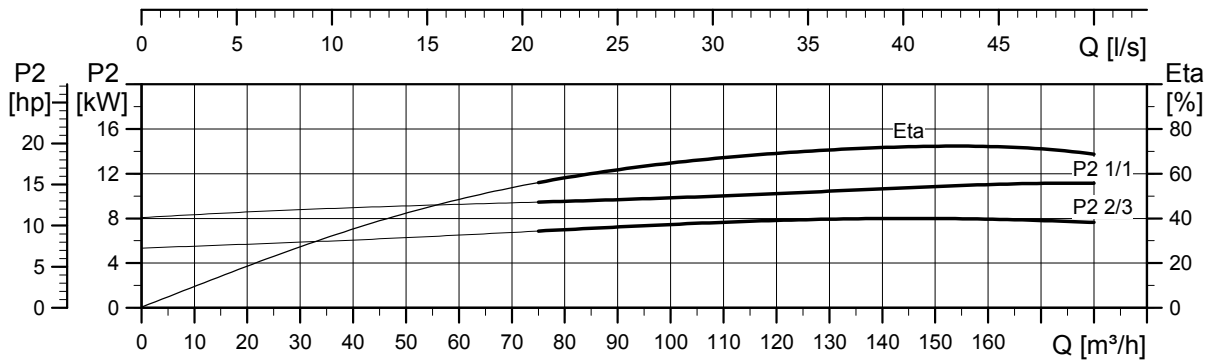
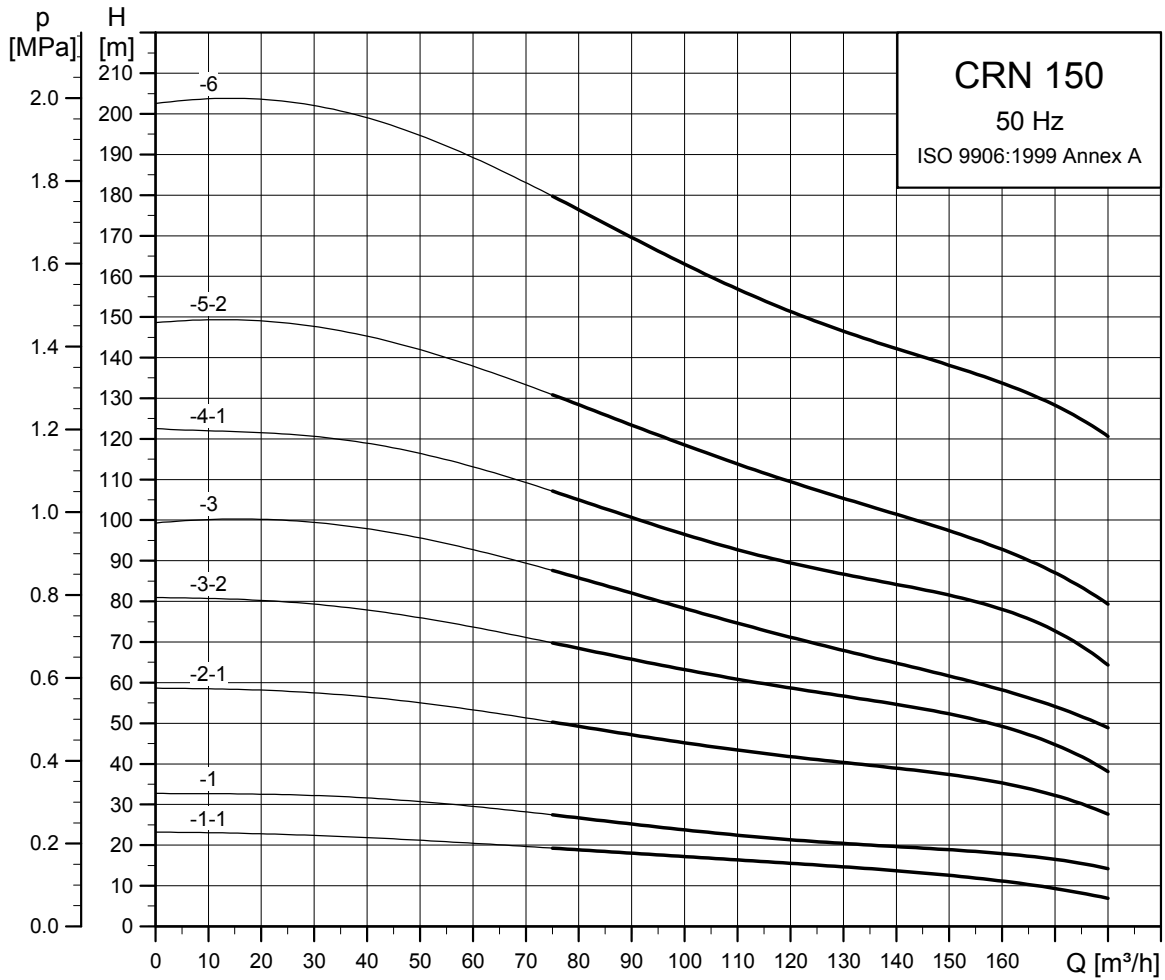

TM03 8746 3513

Dimensional sketch

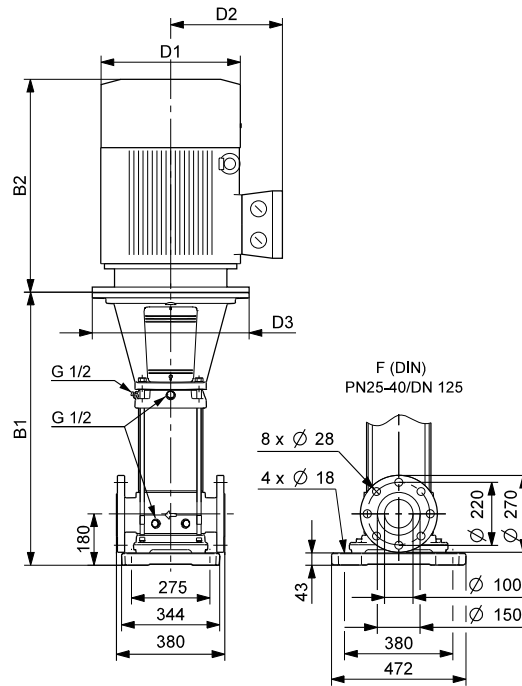

TM03 8889 2707

Dimensions and weights

Pump type	Motor P ₂ [kW]	CRN					Net weight [kg]
		Dimension [mm]					
		B1	B1+B2	D1	D2	D3	
CRN 150-1-1	11.00	834	1305	314	204	350	195
CRN 150-1	15.00	834	1305	314	204	350	208
CRN 150-2-1	22.00	990	1531	314	204	350	245
CRN 150-3-2	30.00	1145	1756	396	315	400	372
CRN 150-3	37.00	1145	1781	396	315	400	387
CRN 150-4-1	45.00	1301	2009	439	338	450	481
CRN 150-5-2	55.00	1486	2233	487	410	550	621
CRN 150-6	75.00	1642	2462	540	433	550	736

6. Motor data

Standard motors for CR, CRI, CRN, 50 Hz

Motor P2 [kW]	Frame size	Standard voltage [V]	$I_{1/1}$ [A]	$\cos \phi_{1/1}$	Efficiency class	η [%]	I_{start} [%]	Speed [min^{-1}]	MG
0.37	71	220-240 Δ / 380-415Y	1.74 / 1.00	0.80-0.70	-	78.5	490-530	2850-2880	
0.55	71	220-240 Δ / 380-415Y	2.50 / 1.44	0.80-0.70	-	80.0	580-620	2830-2850	
0.75	80	220-240 Δ / 380-415Y	3.30 / 1.90	0.81-0.71	IE3	80.7	580-620	2840-2870	
1.1	80	220-240 Δ / 380-415Y	4.35 / 2.50	0.83-0.76	IE3	82.7	450-500	2840-2870	
1.5	90	220-240 Δ / 380-415Y	5.45 / 3.15	0.87-0.82	IE3	84.2	850-930	2890-2910	
2.2	90	380-415 Δ	4.45	0.89-0.87	IE3	85.9	850-950	2890-2910	
3.0	100	380-415 Δ	6.30	0.87-0.82	IE3	87.1	840-920	2900-2920	
4.0	112	380-415 Δ	7.90	0.87	IE3	88.1	1000-1110	2920-2940	
5.5	132	380-415 Δ	11.0	0.87-0.82	IE3	89.2	1080-1180	2920-2940	
7.5	132	380-415 Δ / 660-690Y	14.4-14.0 / 8.30-8.10	0.88-0.82	IE3	90.4	780-910	2910-2920	
11	160	380-415 Δ / 660-690Y	20.8-19.8 / 12.0-11.8	0.88-0.84	IE3	91.2	660-780	2940-2950	
15	160	380-415 Δ / 660-690Y	28.0-26.0 / 16.2-15.6	0.89-0.87	IE3	91.9	660-780	2930-2950	
18.5	160	380-415 Δ / 660-690Y	34.5-32.5 / 20.0-18.8	0.89-0.85	IE3	92.4	830-980	2940-2950	
22	180	380-415 Δ / 660-690Y	39.5 / 22.8	0.90	IE3	92.7	830-830	2950	
Siemens									
30	200	380-420 Δ / 660-725Y	56.0-52.0 / 32.5-30.0	0.86	IE3	93.3	780-780	2955	
37	200	380-420 Δ / 660-725Y	68.0-63.0 / 39.0-36.5	0.86	IE3	93.7	760-760	2950	
45	225	380-420 Δ / 660-725Y	81.0-75.0 / 47.0-43.5	0.89	IE3	94.0	730-730	2960	
55	250	380-420 Δ / 660-725Y	99.0-91.0 / 57.0-53.0	0.89	IE3	94.3	700-700	2975	
75	280	380-420 Δ / 660-725Y	136-126 / 78.0-73.0	0.89	IE3	94.7	720-720	2975	



TM03 1711 2805



TM03 1710 2805

7. Pumped liquids

The pumps are suitable for thin, non-explosive liquids, not containing solid particles or fibres. The liquid must not chemically attack the pump materials.

When pumping liquids with a density and/or viscosity higher than that of water, use oversized motors, if required.

Whether a pump is suitable for a particular liquid depends on a number of factors of which the most important are the chloride content, pH value, temperature, content of chemicals and oils.

Please note that aggressive liquids, such as sea water and some acids, may attack or dissolve the protective oxide film of the stainless steel and thus cause corrosion.

CR and CRI

CR and CRI pumps are suitable for non-corrosive liquids.

Use CR or CRI pumps for liquid transfer, circulation and pressure boosting of cold or hot clean water.

CRN

CRN pumps are suitable for industrial liquids.

Use CRN pumps in systems where all parts in contact with the liquid must be made of high-grade stainless steel.

CRT

For saline or chloride-containing liquids such as sea water or for oxidising agents such as hypochlorites, we offer CRT pumps made of titanium.

See the separate data booklet on CRT, CRTE available on www.Grundfos.com (WebCAPS).

List of pumped liquids

A number of typical liquids are listed below.

Other pump versions may be applicable, but those stated in the list are considered to be the best choices.

The table is intended as a general guide only and cannot replace actual testing of the pumped liquids and pump materials under specific working conditions. However, use the list with some caution. Factors such as those mentioned below may affect the chemical resistance of a specific pump version:

- concentration of the pumped liquid
- liquid temperature
- pressure.

Take safety precautions when pumping dangerous liquids.

Notes

D	Often with additives.
E	The density and/or viscosity differ from that/those of water. Take this factor into account when calculating motor output and pump performance.
F	Pump selection depends on many factors. Contact Grundfos.
H	Risk of crystallisation/precipitation in shaft seal.
1	Highly inflammable liquid.
2	Combustible liquid.
3	Insoluble in water.
4	Low self-ignition point.

Pumped liquid	Chemical formula	Note	Liquid concentration, liquid temperature	CR, CRI	CRN
Acetic acid	CH ₃ COOH	-	5 %, 20 °C	-	HQQE
Acetone	CH ₃ COCH ₃	1, F	100 %, 20 °C	-	HQQE
Alkaline degreasing agent		D, F	-	HQQE	-
Ammonium bicarbonate	NH ₄ HCO ₃	E	20 %, 30 °C	-	HQQE
Ammonium hydroxide	NH ₄ OH	-	20 %, 40 °C	HQQE	-
Aviation fuel		1, 3, 4, F	100 %, 20 °C	HQB	-
Benzoic acid	C ₆ H ₅ COOH	H	0.5 %, 20 °C	-	HQQV
Boiler water		-	< 120 °C	HQQE	-
		F	120-180 °C	-	-
Calcareous water		-	< 90 °C	HQQE	-
Calcium acetate (as coolant with inhibitor)	Ca(CH ₃ COO) ₂	D, E	30 %, 50 °C	HQQE	-
Calcium hydroxide	Ca (OH) ₂	E	Saturated solution, 50 °C	HQQE	-
Chloride-containing water		F	< 30 °C, max. 500 ppm	-	HQQE
Chromic acid	H ₂ CrO ₄	H	1 %, 20 °C	-	HQQV
Citric acid	HOC(CH ₂ CO ₂ H) ₂ COOH	H	5 %, 40 °C	-	HQQE
Completely desalinated water (demineralised water)		-	120 °C	-	HQQE
Condensate		-	120 °C	HQQE	-
Copper sulphate	CuSO ₄	E	10 %, 50 °C	-	HQQE
Corn oil		D, E, 3	100 %, 80 °C	HQQV	-
Diesel oil		2, 3, 4, F	100 %, 20 °C	HQB	-
Domestic hot water (potable water)		-	< 120 °C	HQQE	-
Ethanol (ethyl alcohol)	C ₂ H ₅ OH	1, F	100 %, 20 °C	HQQE	-
Ethylene glycol	HOCH ₂ CH ₂ OH	D, E	50 %, 50 °C	HQQE	-
Formic acid	HCOOH	-	5 %, 20 °C	-	HQQE
Glycerine (glycerol)	OHCH ₂ CH(OH)CH ₂ OH	D, E	50 %, 50 °C	HQQE	-
Hydraulic oil (mineral)		E, 2, 3	100 %, 100 °C	HQQV	-
Hydraulic oil (synthetic)		E, 2, 3	100 %, 100 °C	HQQV	-
Isopropyl alcohol	CH ₃ CHOHCH ₃	1, F	100 %, 20 °C	HQQE	-
Lactic acid	CH ₃ CH(OH)COOH	E, H	10 %, 20 °C	-	HQQV
Linoleic acid	C ₁₇ H ₃₁ COOH	E, 3	100 %, 20 °C	HQQV	-
Methanol (methyl alcohol)	CH ₃ OH	1, F	100 %, 20 °C	HQQE	-
Motor oil		E, 2, 3	100 %, 80 °C	HQQV	-
Naphthalene	C ₁₀ H ₈	E, H	100 %, 80 °C	HQQV	-
Nitric acid	HNO ₃	F	1 %, 20 °C	-	HQQE
Oil-containing water		-	< 100 °C	HQQV	-
Olive oil		D, E, 3	100 %, 80 °C	HQQV	-
Oxalic acid	(COOH) ₂	H	1 %, 20 °C	-	HQQE
Ozone-containing water	(O ₃)	-	< 100 °C	-	HQQE
Peanut oil		D, E, 3	100 %, 80 °C	HQQV	-
Petrol		1, 3, 4, F	100 %, 20 °C	HQB	-
Phosphoric acid	H ₃ PO ₄	E	20 %, 20 °C	-	HQQE
Propanol	C ₃ H ₇ OH	1, F	100 %, 20 °C	HQQE	-
Propylene glycol	CH ₃ CH(OH)CH ₂ OH	D, E	50 %, 90 °C	HQQE	-
Potassium carbonate	K ₂ CO ₃	E	20 %, 50 °C	HQQE	-
Potassium formate (as coolant with inhibitor)	KOOCH	D, E	30 %, 50 °C	HQQE	-
Potassium hydroxide	KOH	E	20 %, 50 °C	-	HQQE
Potassium permanganate	KMnO ₄	-	5 %, 20 °C	-	HQQE
Rape seed oil		D, E, 3	100 %, 80 °C	HQQV	-
Salicylic acid	C ₆ H ₄ (OH)COOH	H	0.1 %, 20 °C	-	HQQE
Silicone oil		E, 3	100 %	HQQV	-
Sodium bicarbonate	NaHCO ₃	E	10 %, 60 °C	-	HQQE
Sodium chloride (as coolant)	NaCl	D, E	30 %, < 5 °C, pH > 8	HQQE	-
Sodium hydroxide	NaOH	E	20 %, 50 °C	-	HQQE
Sodium hypochlorite	NaOCl	F	0.1 %, 20 °C	-	HQQV
Sodium nitrate	NaNO ₃	E	10 %, 60 °C	-	HQQE
Sodium phosphate	Na ₃ PO ₄	E, H	10 %, 60 °C	-	HQQE
Sodium sulphate	Na ₂ SO ₄	E, H	10 %, 60 °C	-	HQQE
Softened water		-	< 120 °C	-	HQQE
Soya oil		D, E, 3	100 %, 80 °C	HQQV	-
Sulphuric acid	H ₂ SO ₄	F	1 %, 20 °C	-	HQQV
Sulphurous acid	H ₂ SO ₃	-	1 %, 20 °C	-	HQQE
Unsalted swimming-pool water		-	Approx. 2 ppm free chlorine (Cl ₂)	HQQE	-

8. Accessories

Pipe connection

Various sets of counter-flanges and couplings are available for pipe connection.

Adapter kit

DN 150 flanges are available for CR, CRN 120 and 150 pumps. To use DN 150 flanges, two adapter kits per pump must be ordered.

Adapter kit	Pump type	Pipe connection	Number of flange kits required	Product number
	CR 120 CR 150	150 mm, nominal	2	96638169
	CRN 120 CRN 150	150 mm, nominal	2	96638180

We offer an optional 6" pump base for the CRN 90, 120 and 150 pump ranges with DN 150 connections according to DIN, ANSI and JIS standards. This base eliminates the need for an adapter kit. For more information, see CR "Custom-built pumps" data booklet on www.grundfos.com (WebCAPS).

Counter-flanges for CR

A set consists of one counter-flange, one gasket, bolts and nuts.

Counter-flange	Pump type	Description	Rated pressure	Pipe connection	Product number
	TM05 0998 2011 CR 1s CR 1 CR 3 CR 5	Threaded	16 bar, EN 1092-2	Rp 1	409901
		For welding	25 bar, EN 1092-2	25 mm, nominal	409902
	TM05 1003 2011 CR 1s CR 1 CR 3 CR 5	Threaded	16 bar, EN 1092-2	Rp 1 1/4	419901
		For welding	25 bar, EN 1092-2	32 mm, nominal	419902
	TM05 1002 2011 CR 10	Threaded	16 bar, EN 1092-2	Rp 1 1/2	429902
		Threaded	16 bar, EN 1092-2	Rp 2	429904
		For welding	25 bar, EN 1092-2	40 mm, nominal	429901
		For welding	40 bar, special flange	50 mm, nominal	429903

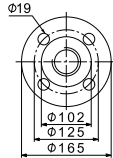
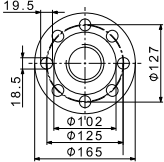
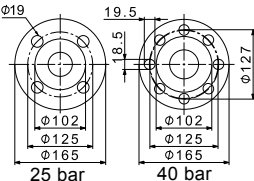
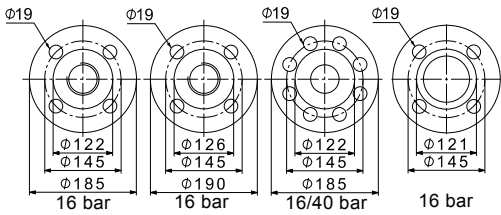
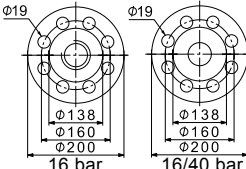
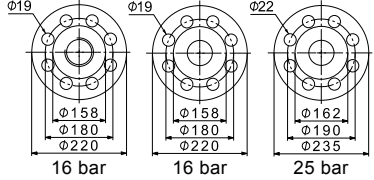
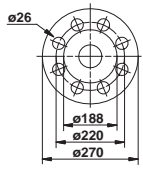
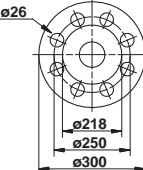
Counter-flange	Pump type	Description	Rated pressure	Pipe connection	Product number	
	TM05 0999 2011	Threaded	16 bar, EN 1092-2	Rp 2	339903	
		Threaded	16 bar, special flange	Rp 2 1/2	339904	
	TM05 1005 2011	CR 15 CR 20	Threaded	16 bar, special flange	Rp 2 1/2*	96509578
	TM05 1000 2011	For welding	25 bar, EN 1092-2	50 mm, nominal	339901	
		For welding	40 bar, special flange	65 mm, nominal	339902	
	TM05 0997 2011	CR 32	Threaded	16 bar, EN 1092-2	Rp 2 1/2	349902
		Threaded	16 bar, special flange	Rp 3	349901	
		For welding	16 bar, EN 1092-2	65 mm, nominal	349904	
		For welding	40 bar, DIN 2635	65 mm, nominal	349905	
		For welding	16 bar, special flange	80 mm, nominal	349903	
	TM05 0996 2011	CR 45	Threaded	16 bar	Rp 3	350540
		For welding	16 bar	80 mm, nominal	350541	
		For welding	40 bar	80 mm, nominal	350542	
	TM05 0995 2011	CR 64 CR 90	Threaded	16 bar, EN 1092-2	Rp 4	369901
		For welding	16 bar, EN 1092-2	100 mm, nominal	369902	
		For welding	25 bar, EN 1092-2	100 mm, nominal	369905	
	TM03 8892 2707	CR 120 CR 150	For welding	40 bar, EN 1092-2	125 mm, nominal	96750475
	TM03 8891 2707		For welding	40 bar, EN 1092-2	150 mm, nominal	96750476



* Flange with 20 mm higher collar. With this collar, the installation dimensions of a CR 20 will be identical to those of a CR 32. If a CR 32 is replaced by a CR 20, the base must be raised by 15 mm.

Counter-flanges for CRN

Counter-flanges for CRN pumps are made of stainless steel EN 1.4401 (AISI 316).

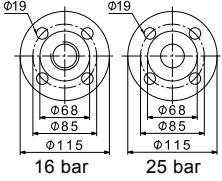
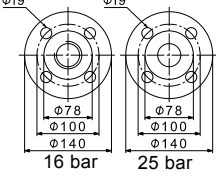
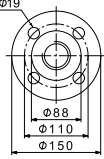
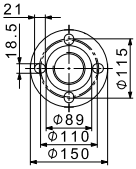
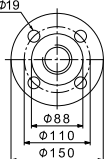
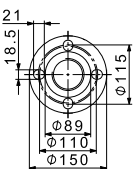
A set consists of one counter-flange, one gasket, bolts and nuts.

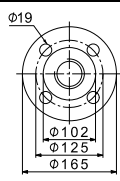
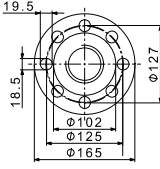
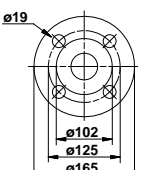
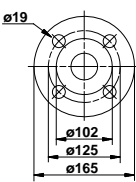
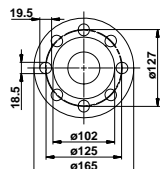
Counter-flange	Pump type	Description	Rated pressure	Pipe connection	Product number
	TM05 0998 2011 CRN 1s, 1, 3, 5	Threaded	16 bar, EN 1092-2	Rp 1	405284
		For welding	25 bar, EN 1092-2	25 mm, nominal	405285
	TM05 1003 2011 CRN 1s, 1, 3, 5	Threaded	16 bar, EN 1092-2	Rp 1 1/4	415304
		For welding	25 bar, EN 1092-2	32 mm, nominal	415305
	TM05 1001 2011	Threaded	16 bar, EN 1092-2	Rp 1 1/2	425245
	TM05 1006 2011 CRN 10	Threaded	16 bar, EN 1092-2	Rp 2	96509570
	TM05 1001 2011	For welding	25 bar, EN 1092-2	40 mm, nominal	425246
	TM05 1006 2011	For welding	25 bar, special flange	50 mm, nominal	96509571

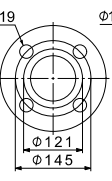
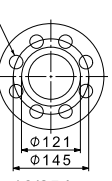
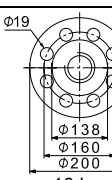
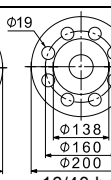
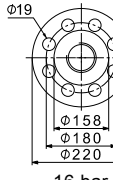
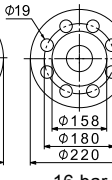
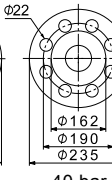
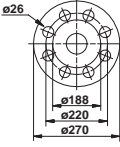
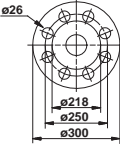
Counter-flange	Pump type	Description	Rated pressure	Pipe connection	Product number
	TM05 0999 2011	Threaded	16 bar, EN 1092-2	Rp 2	335254
	TM05 1005 2011	Threaded	16 bar, special flange	Rp 2 1/2	96509575
		Threaded	16 bar, special flange	Rp 2 1/2*	96509579
	TM03 0402 2011	For welding	25 bar, EN 1092-2	50 mm, nominal	335255
	TM00 7203 2803	For welding	25 bar, special flange	65 mm, nominal	96509573
	TM05 0994 2011	Threaded	16 bar	Rp 2 1/2	349910
		Threaded	16 bar, special flange	Rp 3	349911
		For welding	16 bar	65 mm, nominal	349906
		For welding	40 bar	65 mm, nominal	349908
		For welding	16 bar, special flange	80 mm, nominal	349907
		For welding	25 bar, special flange	80 mm, nominal	349909
	TM05 0996 2011	Threaded	16 bar	Rp 3	350543
		For welding	16 bar	80 mm, nominal	350544
		For welding	40 bar	80 mm, nominal	350545
	TM05 0995 2011	Threaded	16 bar	Rp 4	369904
		For welding	16 bar	100 mm, nominal	369903
		For welding	40 bar	100 mm, nominal	369906
	TM03 8892 2707	For welding	40 bar, EN 1092-2	125 mm, nominal	96750477
	TM03 8891 2707	For welding	40 bar, EN 1092-2	150 mm, nominal	96750478

* Flange with 20 mm higher collar. With this collar, the installation dimensions of a CR 20 will be identical to those of a CR 32.
If a CR 32 is replaced by a CR 20, the base must be raised by 15 mm.

PJE couplings for CRN

Materials in contact with the pumped liquid are made of stainless steel EN 1.4401 (AISI 316) and rubber.

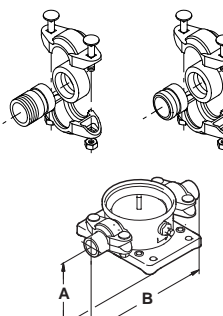

A set consists of two coupling halves (Victaulic type 77), one gasket, one pipe stub (for welding or threaded), bolts and nuts.

Coupling	Pump type	Pipe stub	PN	A	B	Pipe connection	Rubber parts	Number of coupling sets required	Product number		
	TM00 3808 1094 CRN 1s, 1, 3, 5	Threaded	80	50	320	R 1 1/4	EPDM	2	419911		
								FKM	2	419905	
		For welding	80	50	280	DN 32		EPDM	2	419912	
									FKM	2	419904
		TM03 8890 2707 CRN 10, 15, 20	Threaded	70	80	377	R 2		EPDM	2	339911
									FKM	2	339918
For welding	70		80	371	DN 50		EPDM	2	339910		
								FKM	2	339917	

FlexiClamp base connections

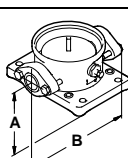
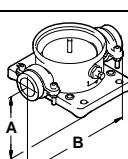
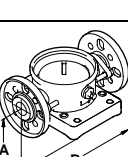
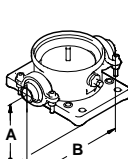
All sets comprise the necessary number of bolts and nuts as well as a gasket/O-ring.

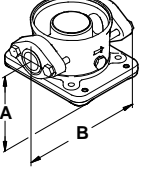
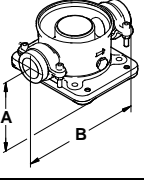
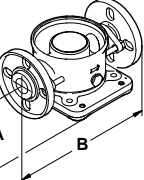
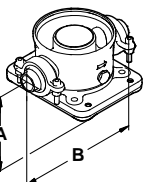
Base connection	Pump type	Connection	Pipe connection	PN	A	B	Rubber parts	Number of coupling sets required	Product number		
	TM02 7368 3303 CRI CRN 1s, 1, 3, 5	Oval (cast iron)	Rp 1	16	50	210	Klingersil	1	96449748		
			Rp 1 1/4					1	96449749		
		Oval (stainless steel)	Rp 1		2	96449746					
			Rp 1 1/4		2	96449747					
	TM02 7369 3303 CRI CRN 1s, 1, 3, 5	Union	G 2	25	50	228	EPDM	2	96449743		
							FKM	2	96449744		
	TM02 7370 3303 CRI CRN 1s, 1, 3, 5	DIN (stainless steel)	DN 25	16	75	250	EPDM	2	96449745		
			DN 32					FKM	2	96449900	
	TM02 7371 3303 CRI CRN 1s, 1, 3, 5	Clamp, threaded pipe stub	Rp 1	25	50	208	EPDM	2	405280		
								FKM	2	405281	
			Rp 1 1/4					EPDM	2	415296	
								FKM	2	415297	
			1" NPT					EPDM	2	405291	
								FKM	2	405292	
			1 1/4" NPT					EPDM	2	415311	
								FKM	2	415312	
			Clamp, pipe stub for welding				28.5		EPDM	2	405282
									FKM	2	405283
37.2		EPDM		2	415300						
			FKM	2	415301						

Base connection	Pump type	Connection	Pipe connection	PN	A	B	Rubber parts	Number of coupling sets required	Product number	
	CRI 10 CRN 10	Oval (cast iron)	Rp 1 1/4	16	80	260	Klingersil	2	96498775	
			Rp 1 1/2					2	96498727	
			Rp 2					2	96498836	
			Rp 1 1/4					2	96498776	
			Oval (stainless steel)					Rp 1 1/2	2	96498728
			Rp 2					2	96498835	
	CRI 10 CRN 10	Union	G 2 3/4	25	80	288	EPDM	2	96500275	
							FKM	2	96500276	
	CRI 10 CRN 10	FGJ (cast iron)	DN 40	16	80	316	EPDM	2	96498840	
							FKM	2	96500119	
							FGJ (stainless steel)	EPDM	2	96500263
								FKM	2	96500264
							FGJ (cast iron)	EPDM	2	96500265
								FKM	2	96500266
	CRI 10 CRN 10	FGJ (stainless steel)	DN 50	25	80	346	EPDM	2	96500267	
							FKM	2	96500269	
							Rp 1 1/2	EPDM	2	425238
								FKM	2	425239
							Clamp, threaded pipe stub	EPDM	2	335241
								FKM	2	335242
	CRI 10 CRN 10	Clamp, pipe stub for welding	Rp 2 1/2	25	80	346	EPDM	2	96508600	
			FKM				2	96508601		
			48.3 (DN 40)				EPDM	2	425242	
							FKM	2	425243	
			60.3 (DN 50)				EPDM	2	335251	
							FKM	2	335252	

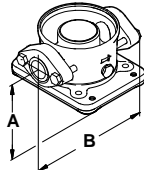
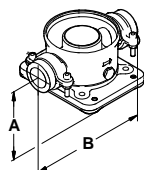
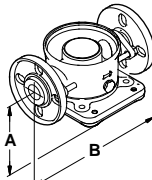
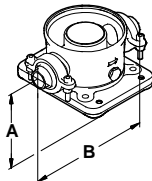
Base connection	Pump type	Connection	Pipe connection	PN	A	B	Rubber parts	Number of coupling sets required	Product number								
	CRI 15, 20 CRN 15, 20	Oval (cast iron)	Rp 1 1/4	10	90	260	Klingersil	2	96498775								
			Rp 1 1/2					2	96498727								
			Rp 2					2	96498836								
			Rp 1 1/4					2	96498776								
			Oval (stainless steel)					Rp 1 1/2	2	96498728							
			Rp 2					2	96498835								
	CRI 15, 20 CRN 15, 20	Union	G 2 3/4	25	90	288	EPDM	2	96500275								
							FKM	2	96500276								
	CRI 15, 20 CRN 15, 20	FGJ (cast iron)	DN 40	10	90	334	EPDM	2	96498840								
							FKM	2	96500119								
							FGJ (stainless steel)	EPDM	2	96500263							
							FKM	2	96500264								
							FGJ (cast iron)	EPDM	2	96500265							
							FKM	2	96500266								
	CRI 15, 20 CRN 15, 20	FGJ (stainless steel)	DN 50	25	90	346	EPDM	2	96500267								
							FKM	2	96500269								
							Rp 1 1/2	EPDM	2	425238							
											FKM	2	425239				
														259	EPDM	2	335241
Rp 2	EPDM	2	96508600														
				FKM	2	96508601											
Clamp, threaded pipe stub	EPDM	2	425242														
				FKM	2	425243											
							EPDM	2	335251								
				FKM	2	335252											
48.3 (DN 40)	EPDM	2	425242														
				FKM	2	425243											
Clamp, pipe stub for welding	EPDM	2	335251														
				FKM	2	335252											

LiqTec

The LiqTec dry-running protection unit protects the pump and process against dry running and temperatures exceeding $130\text{ °C} \pm 5\text{ °C}$. Connected to the motor PTC sensor, the LiqTec also monitors the motor temperature.

The LiqTec is prepared for DIN rail mounting in control cabinet.

Enclosure class: IPX0.

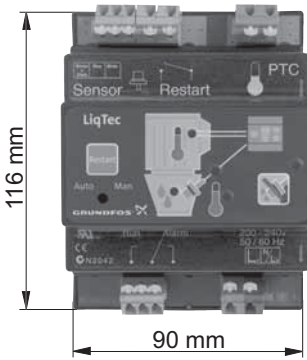
LiqTec unit	Pump type	Voltage [V]	LiqTec	Sensor 1/2"	Cable 5 m	Extension cable 15 m	Product number
	CR CRI CRN	200-240	•	•	•	-	96556429
		80-130	•	•	•	-	96556430
		-	-	-	-	•	96443676

TM03 2108 3705

Sensors

Sensor	Type	Supplier	Measuring range	Product number
Flowmeter	SITRANS FM MAGFLO MAG 5100 W	Siemens	1-5 m ³ (DN 25)	ID8285
	SITRANS FM MAGFLO MAG 5100 W		3-10 m ³ (DN 40)	ID8286
	SITRANS FM MAGFLO MAG 5100 W		6-30 m ³ (DN 65)	ID8287
	SITRANS FM MAGFLO MAG 5100 W		20-75 m ³ (DN 100)	ID8288
Temperature sensor	TTA (0) 25	Carlo Gavazzi	0-25 °C	96432591
	TTA (-25) 25		-25 - +25 °C	96430194
	TTA (50) 100		50-100 °C	96432592
	TTA (0) 150		0-150 °C	96430195
Accessory for temperature sensor. All with 1/2 RG connection	Protecting tube Ø9 x 50 mm	Carlo Gavazzi		96430201
	Protecting tube Ø9 x 100 mm			96430202
	Cutting ring bush			96430203
Temperature sensor, ambient temperature	WR 52	tmg (DK: Plesner)	-50 - +50 °C	ID8295
Differential-temperature sensor	ETSD	Honsberg	0-20 °C	96409362
	ETSD		0-50 °C	96409363

Note: All sensors have 4-20 mA signal output.

Danfoss pressure sensor kits

Content	Liquid temperature	Pressure [bar]	Product number
<ul style="list-style-type: none"> Danfoss pressure transmitter, type MBS 3000, with 2 m screened cable. Connection: G 1/2 A (DIN 16288 - B6kt) 5 cable clips (black) Instructions PT (400212) 	-40 - +85 °C	0-4	96428014
		0-6	96428015
		0-10	96428016
		0-16	96428017
		0-25	96428018

DPI differential-pressure sensor kit

Content	Pressure [bar]	Product number
<ul style="list-style-type: none"> 1 sensor incl. 0.9 m screened cable (7/16" connections) 1 original DPI bracket for wall mounting 1 Grundfos bracket for mounting on motor 2 M4 screws for mounting of sensor on bracket 1 M6 screw (self-cutting) for mounting on MGE 90/100 1 M8 screw (self-cutting) for mounting on MGE 112/132 3 capillary tubes (short/long) 2 fittings (1/4" - 7/16") 5 cable clips (black) Installation and operating instructions (00480675) Service kit instructions. 	0 - 0.6	96611522
	0 - 1.0	96611523
	0 - 1.6	96611524
	0 - 2.5	96611525
	0 - 4.0	96611526
	0 - 6.0	96611527
	0 - 10	96611550

9. Variants

The variants are available on request.

Although the Grundfos CR, CRI, CRN product range offers a number of pumps for different applications, customers require specific pump solutions to satisfy their needs. See the following documents:

- Grundfos CR "Custom-built pumps" data booklet
- Grundfos "CR, CRN high pressure" data booklet.

Below please find the range of options available for customising the CR pumps to meet the customers' demands.

Contact Grundfos for further information or for requests other than the ones mentioned below.

Motors

Variant	Description
ATEX-approved motor	For operation in hazardous atmospheres, explosion-proof or dust-ignition-proof motors may be required.
Motor with anti-condensation heating unit	For operation in humid environments motors with built-in anti-condensation heating unit may be required.
Motor with thermal protection	We offer motors with built-in bimetallic thermal switches or temperature-controlled PTC sensors (thermistors) incorporated in the motor windings.
Oversize motor	Ambient temperatures above 40 °C or installation at altitudes of more than 1000 metres above sea level require the use of an oversize motor (i.e. derating).
4-pole motor	We offer 4-pole standard motors.

Shaft seals

Variant	Description
Shaft seal with FFKM O-ring	Shaft seals with FFKM or FXM O-ring are recommended for applications where the pumped liquid may damage the standard O-ring material.
Seal with flush, quench seal	Recommended for applications involving crystallising, hardening or sticky liquids.
Air-cooled shaft seal system	Recommended for applications involving extremely high temperatures. No conventional mechanical shaft seal can withstand liquid temperatures of up to 180 °C for any length of time. For such applications, Grundfos' unique air-cooled shaft seal system is recommended. In order to ensure a low liquid temperature around the standard shaft seal, the pump is fitted with a special air-cooled shaft seal chamber. No separate cooling is required.
Double seal with pressure chamber	Recommended for applications involving poisonous or explosive liquids. Protects the surrounding environment and the people working in the vicinity of the pump. Consists of two seals mounted in a "back-to-back" arrangement inside a separate pressure seal chamber. As the pressure in the chamber is higher than the pump pressure, leakage is prevented. A dosing pump or a special pressure intensifier generates the seal chamber pressure.
CR MAGdrive	Magnetically driven pumps for industrial applications. Key applications are industrial processes involving the handling of aggressive, environmental, dangerous or volatile liquids, e.g. organic compounds, solvents, etc.

Pumps

Variant	Description
Horizontally mounted pump	For safety or height reasons, certain applications, for instance on ships, require the pump to be mounted in the horizontal position. For easy installation the pump is fitted with brackets that support motor and pump.
Low-temperature pump	Exposed to temperatures down to -40 °C, coolant pumps may require neck rings with a different diameter in order to prevent impeller drag.
High-pressure pump up to 47 bar	For high-pressure applications, we offer a unique double pump system capable of generating a pressure of up to 47 bar.
Low-NPSH pump (improved suction)	Recommended for boiler-feed applications where cavitation may occur due to poor inlet conditions.
Pump with bearing flange	The bearing flange is suitable for applications where the inlet pressure is higher than the maximum pressure recommended. The bearing flange increases the life of motor bearings. Recommended for standard motors.
Belt-driven pump	Belt-driven pumps designed to operate in places with limited space or where no electrical power is available.
Pump for pharmaceutical and biotechnological applications	CRN pumps designed for applications requiring the sterilisation and CIP capability of pipes, valves and pumps. (CIP = Cleaning-In-Place.)

Connections and other variants

Variant	Description
Pipe connections	In addition to the wide range of standard flange connections, a 16 bar DIN standard clamping flange is available. Customized flanges are available according to specifications.
TriClamp connection	TriClamp connections are of a hygienic design with a sanitary coupling for use in the pharmaceutical and food industry.
Electropolished pump	To substantially reduce the risk of corrosion of the materials. For use in the pharmaceutical and food industry.

10. Further product information

WebCAPS

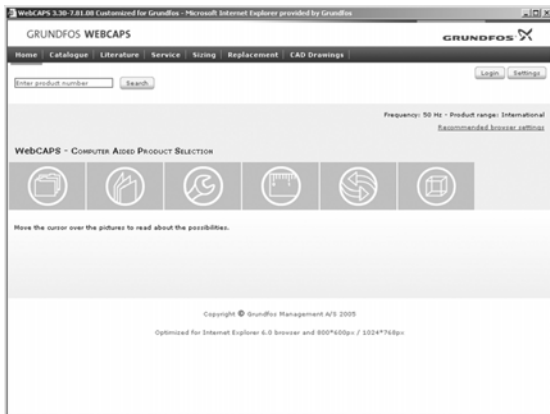

WebCAPS is a **Web-based Computer Aided Product Selection** program available on www.grundfos.com.

WebCAPS contains detailed information on more than 220,000 Grundfos products in more than 30 languages.

Information in WebCAPS is divided into six sections:

- Catalogue
- Literature
- Service
- Sizing
- Replacement
- CAD drawings.



Catalogue

Based on fields of application and pump types, this section contains the following:

- technical data
- curves (QH, Eta, P1, P2, etc.) which can be adapted to the density and viscosity of the pumped liquid and show the number of pumps in operation
- product photos
- dimensional drawings
- wiring diagrams
- quotation texts, etc.

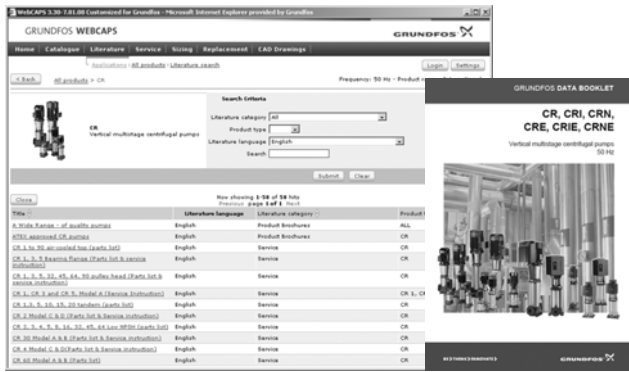

Literature

This section contains all the latest documents of a given pump, such as

- data booklets
- installation and operating instructions
- service documentation, such as Service kit catalogue and Service kit instructions
- quick guides
- product brochures.

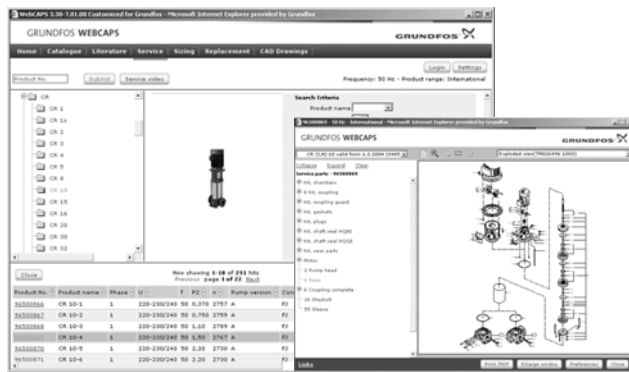

Service

This section contains an easy-to-use interactive service catalogue. Here you can find and identify service parts of both existing and discontinued Grundfos pumps.

Furthermore, the section contains service videos showing you how to replace service parts.



Sizing

This section is based on different fields of application and installation examples and gives easy step-by-step instructions in how to size a product:

- Select the most suitable and efficient pump for your installation.
- Carry out advanced calculations based on energy, consumption, payback periods, load profiles, life cycle costs, etc.
- Analyse your selected pump via the built-in life cycle cost tool.
- Determine the flow velocity in wastewater applications, etc.



Replacement

In this section you find a guide to selecting and comparing replacement data of an installed pump in order to replace the pump with a more efficient Grundfos pump. The section contains replacement data of a wide range of pumps produced by other manufacturers than Grundfos.

Based on an easy step-by-step guide, you can compare Grundfos pumps with the one you have installed on your site. When you have specified the installed pump, the guide will suggest a number of Grundfos pumps which can improve both comfort and efficiency.

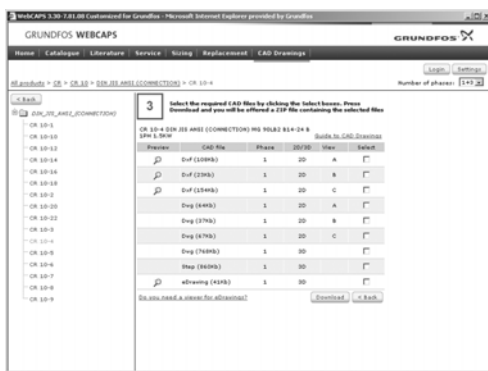

CAD drawings

In this section, it is possible to download 2-dimensional (2D) and 3-dimensional (3D) CAD drawings of most Grundfos pumps.

These formats are available in WebCAPS:

- 2-dimensional drawings:**
- .dxf, wireframe drawings
 - .dwg, wireframe drawings.
- 3-dimensional drawings:**
- .dwg, wireframe drawings (without surfaces)
 - .stp, solid drawings (with surfaces)
 - .eprt, E-drawings.



WinCAPS



Fig. 18 WinCAPS DVD

WinCAPS is a **Windows-based Computer Aided Product Selection** program containing detailed information on more than 220,000 Grundfos products in more than 30 languages.

The program contains the same features and functions as WebCAPS, but is an ideal solution if no internet connection is available.

WinCAPS is available on DVD and updated once a year.

GO CAPS

Mobile solution for professionals on the GO!



CAPS functionality on the mobile workplace.



Subject to alterations.

V7023751 1113
ECM: 1124243